



964 Carrera 4 Cabriolet at the 1989 Motor Show, London

## 964 History

*by Ken Chambers, PCGB 964 Registry Secretary and Sideways Sid, PCGB 964 Owner*

That the Porsche 911 is legendary in the world of performance cars is unquestionable.

With its distinctive shape and totally individual character the 911 has appealed to driving enthusiasts since its introduction in 1963. In 1989 the first major update resulted in the 964 model in the four-wheel drive Carrera 4 (Built on the experience of the Porsche 959). A year later followed the two-wheel drive Carrera 2. Production of these cars ran from 1989 up until 1993 and the introduction of the 993. During this period some 3,692 were imported into the United Kingdom.

Although over 85% of the components had been redesigned, the body style remain faithful to the classic lines of the 911.

Improved aerodynamics using knowledge gained from Le Mans winning 959 and 962, reduced the drag coefficient to 0.32, and with virtually zero lift greatly improved stability and road holding at high speed. A retractable rear spoiler automatically extends at 50mph and whilst increasing the downforce also doubles the volume of air intake for improved engine cooling. The spoiler automatically retracts at below 60 mph.

The capacity of the famous flat six engine increased to 3.6 Litres. Gained twin spark ignition and become the most powerful normally aspirated 911 production engine with 250 bhp and 310 Nm of torque at 4,800 rpm, 0-60 coming up in just over 5 seconds and a top speed of 162 mph

Tiptronic Electro-hydraulically controlled 4 speed transmission was as an option for the first

time, giving the combination of manual and automatic gear selection being supplemented by immediate up or down gear selection by 'tipping' the gear lever forward or backwards.

Compared to earlier versions the 964 also gained from chassis development and improvements in tyre technology, resulting in far more user friendly driving characteristics on the limit, whilst still retaining enough quirkiness of a rear engine design to satisfy and reward enthusiastic drivers.

The introduction of an anti-lock dual assisted braking system, progressive power steering, 3-way catalytic converter and a ten-year anti-corrosion warranty completed the new package.

Offered in Coupe, Targa and Cabriolet versions, the enthusiast was spoilt for choice. A lightweight version the 964 RS followed, and a turbo charged version the 965 maintain the lineage of the 911 family.

# Complete 964

4

## HISTORY



### Drive Train

### Brakes

### Wheels

### Body

### Suspension

### Engine

### Interior

### Floor Plan

The Porsche 911 for the model years 1989 (introduced November 1988) to 1993, designated Porsche 964, was developed in response to the dramatic decrease in sales of the Porsche 911 Carrera 3.2.

In an attempt to win back the old Porsche enthusiast, the company realised that a completely new driving experience would have to be developed, one that would captivate the imagination of the sports car enthusiast. To this end, Porsche decided to embrace the advent of a new concept that Audi had stumbled upon a few years before- four wheel drive in a sports coupe.

The birth of four wheel drive technology within Porsche arrived with the introduction of the Porsche 959, a superlative (and extremely expensive) automobile, loosely based on the 911 but showcasing all of the company's highest end technology. After the success of the 959, it was determined that a "working man's" 959 should be developed to take advantage of the reputation gained by the 959 (and its four wheel drive technology).

And so was born the Carrera 4, Porsche's first foray into an affordable full time four wheel drive performance automobile, and the first of the 964 family. I have since received confirmation that the 911C4 is actually based not on the 959 from which only the steering was inherited, but actually the Porsche 953 which was the AWD version of the 911SCRS or Porsche 954. The 953 was built and rallied in 1983 and 1984 winning the Kenyan Safari Rally. By comparison, the derivative of the 959 transmission was not used in



the standard C4. Instead, these 959 derivative transmissions were used in the lightweight C4s (also called the 911 C4RS of which 20 were sold- see **[Variants]** section).

In the attached pages, you will find a detailed description of the changes made to the 964 when compared to the earlier Carrera 3.2 (produced from 1984 to 1989- the predecessor to the 964), and a brief comparison to the car that replaced the 964, the 993.



## MODIFICATIONS

### Suspension

### Wheels

As with all 911's, the Porsche 964 is easily modified to provide additional handling and performance. It should be noted that, as with any automobile manufacturer, Porsche attempts to build automobiles that will be accepted by a majority of people as well as meet strict governmental and environmental regulations. As such, compromises will always be made, and it will always be possible to extract more out of almost any automobile, the 964 not excluded.

Every car enthusiasts (or is that hot rodders?) dream is to customise his ride, to make his car the fastest on the block (we are of course not talking about the true collectors who pride originality). Indeed, given the relatively common nature of the 964, this is one of the best Porsche's to modify given they are not extremely rare.

The level of modifications that can be done to a 964 is largely dependant upon which variant is chosen. Obviously, the owner of a fully optioned RS or Turbo would have far less to do than the owner of a "grass roots" 964.

On the following pages you will find discussions on some of the most common modifications that can be done to the 964- "extreme" modifications for race use are not within the ambit of this website, although as time permits, such modifications may gradually be included in our discussions.

Over time, it is the authors intent that the pages on Modifications move away from a summary of what can be done (and what is for all intents and purposes the author's personal wish list!), to what has been done, and is proven. The author hopes to achieve this by first hand discussions with those who have done particular modifications, as well as through his own experience (via modifications that he has or will perform on his personal ride).



The king of Porsche modifiers (in the authors opinion!), RUF and the company's interpretation of the ultimate 964, a narrow body Carrera 4 or 2 modified into a fire breathing turbo, model designation RCT.

### 1989-91 911 Carrera 4 (type964)

Displacement (cc)	3,600
Horsepower (ps/rpm)	250/6,100
Torque (kgm/rpm)	31.6/4,800
Wheel Base (mm)	2,272
Track front/rear (mm)	1,380/1,374
Length (mm)	4,245
Width (mm)	1660
Weight (kg)	1,450
Maximum Speed (km/h)	260
Production	-

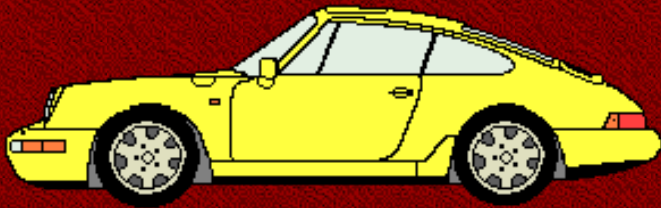

### 1990-91 911 Carrera 2 (type964)

Displacement (cc)	3,600
Horsepower (ps/rpm)	250/6,100
Torque (kgm/rpm)	31.6/4,800
Wheel Base (mm)	2,272
Track front/rear (mm)	1,380/1,385
Length (mm)	4,245
Width (mm)	1,660
Weight (kg)	1,350
Maximum Speed (km/h)	260
Production	-

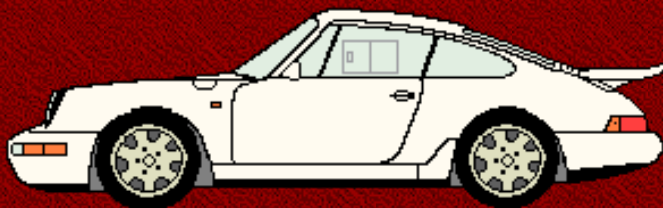

### 1991 911 Carrera 4 Light weight (type964)

Displacement (cc)	3,600
Horsepower (ps/rpm)	250/6,720
Torque (kgm/rpm)	31.5/4,800
Wheel Base (mm)	2,272
Track front/rear (mm)	1,380/1,374
Length (mm)	4,250
Width (mm)	1,651
Weight (kg)	1,100
Maximum Speed (km/h)	-
Production	-

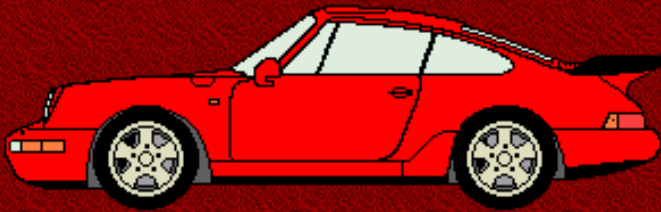

### 1991-92 911 turbo 3.3 (type964)

Displacement (cc)	3,299
Horsepower (ps/rpm)	320/5,750
Torque (kgm/rpm)	45.9/4,500
Wheel Base (mm)	2,271
Track front/rear (mm)	1,434/1,526
Length (mm)	4,250
Width (mm)	1,775
Weight (kg)	1,470
Maximum Speed (km/h)	270
Production	4,107

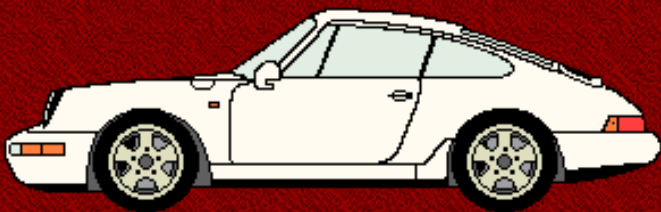

### 1991-92 911 Carrera 2 CUP (type964)

Displacement (cc)	3,600
Horsepower (ps/rpm)	265/6,720
Torque (kgm/rpm)	31.6/4,800
Wheel Base (mm)	2,271
Track front/rear (mm)	1,410/1,415
Length (mm)	4,250
Width (mm)	1,660
Weight (kg)	1,130
Maximum Speed (km/h)	-
Production	233



### 1992 911 turbo S (type964)

Displacement (cc)	3,299
Horsepower (ps/rpm)	381/6,000
Torque (kgm/rpm)	50/5,000
Wheel Base (mm)	2,271
Track front/rear (mm)	1,434/1,493
Length (mm)	4,250
Width (mm)	1,775
Weight (kg)	1,280
Maximum Speed (km/h)	290
Production	80



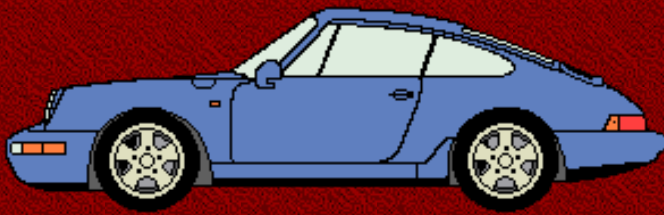

### 1992 911 Carrera RS (type964)

Displacement (cc)	3,600
Horsepower (ps/rpm)	260/6,100
Torque (kgm/rpm)	32/5,000
Wheel Base (mm)	2,271
Track front/rear (mm)	1,380/1,385
Length (mm)	4,250
Width (mm)	1,660
Weight (kg)	1,230
Maximum Speed (km/h)	260
Production	2,051

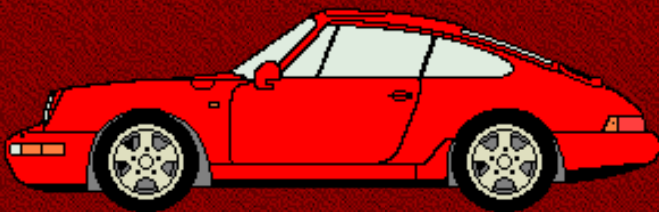

### 1992-93 911 Carrera 4 (type964)

Displacement (cc)	3,600
Horsepower (ps/rpm)	250/6,100
Torque (kgm/rpm)	31.6/4,800
Wheel Base (mm)	2,272
Track front/rear (mm)	1,380/1,374
Length (mm)	4,245
Width (mm)	1,660
Weight (kg)	1,450
Maximum Speed (km/h)	260
Production	-



**1993 911 Carrera RS 3.8 (type964)**

Displacement (cc)	3,746
Horsepower (ps/rpm)	300/6,500
Torque (kgm/rpm)	36.7/5,250
Wheel Base (mm)	2,270
Track front/rear (mm)	1,434/1,493
Length (mm)	4,270
Width (mm)	1,780
Weight (kg)	1,210
Maximum Speed (km/h)	270
Production	129

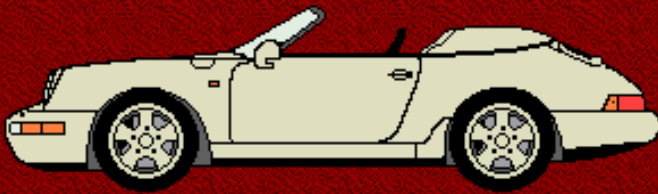

**1993-94 911 Carrera Speedster (type964)**

Displacement (cc)	3,600
Horsepower (ps/rpm)	250/6,100
Torque (kgm/rpm)	31.6/4,800
Wheel Base (mm)	2,272
Track front/rear (mm)	1,380/1,374
Length (mm)	4,245
Width (mm)	1,660
Weight (kg)	1,350
Maximum Speed (km/h)	-
Production	1,986

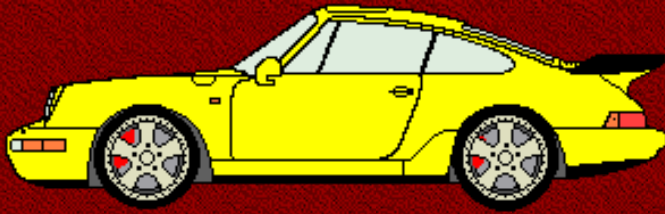

**1993-94 911 turbo 3.6 (type964)**

Displacement (cc)	3,600
Horsepower (ps/rpm)	360/5,500
Torque (kgm/rpm)	53/4,200
Wheel Base (mm)	2,272
Track front/rear (mm)	1,422/1,488
Length (mm)	4,275
Width (mm)	1,775
Weight (kg)	1,470
Maximum Speed (km/h)	280
Production	1,875



**1993 911 Carrera 4 turbo look (type964)  
30 Jahre 911 'Anniversary'**

Displacement (cc)	3,600
Horsepower (ps/rpm)	250/6,100
Torque (kgm/rpm)	31.6/4,800
Wheel Base (mm)	-
Track front/rear (mm)	-
Length (mm)	-
Width (mm)	-
Weight (kg)	1,500
Maximum Speed (km/h)	255

Here's what your VIN number means:

	W	P	O	AA	0	9	1	0	B	S	1	2	0	0	0	1
	/	/	/	^^^	^	^	^	^	^	^	^	^	^	^	^	^
Porsche	/	/	/													
world	/	/	/													
producer	/	/	/													
code	/	/	/													
VDS:	/	/	/													
1: body	/	/	/													
A=coupe	/	/	/													
E=targa	/	/	/													
or cabrio	/	/	/													
J=turbo	/	/	/													
2: dest.	/	/	/													
A=Canada	/	/	/													
B=USA	/	/	/													
3: restraint	/	/	/													
system	/	/	/													
0=passive	/	/	/													
1=active	/	/	/													
If all digits are	/	/	/													
zzz, car is RoW	/	/	/													

four digit serial number

Body + engine code:

0 - RoW (Rest of World) SC/Carrera

1 - RoW Turbo Targa

2 - US SC/Carrera

4 - RoW Targa

5 - Turbo Coupe US or RoW Cabrio

6 - US Targa

7 - US Cabrio

3rd digit of type (e.g. 1, 0, 9)

Manufacture location (S=Stuttgart)

Model year (B=81, C=82,etc.)

Test Digit (value varies, don't know how)

1st & 2nd digits of type (e.g. 91, 93, 95)

Note that in model year codes, I,O and Q are not used.

Thus my Car - VIN: **WPOzzz96zLS401228** is a RoW Porsche 964 Carrera, 1990, built in Stuttgart, the 1228th of the build. [Laseric's 911](#) site has a full list of the [VIN number and engine number ranges here](#).

## Engine Codes

The Engine Code starts with M6401, identifying the standard 3.6L engine, the digits following are the serial number of the engine.

## Option Codes

Your factory-fitted Option codes are on the sticker in your Guarantee and Maintenance handbook page 4, item 5. You can type these codes into Charlie Kindel's [Option Decoder](#), or take a look at Adrian Streather's pretty full [Option List](#). And [Laseric](#) has them in [French](#).

# 911

## 901 Coupé



9/1964-11/1964

1991 ccm, 130 PS

## 911 Coupé 2.0



11/1964-7/1967

1991 ccm, 130 PS

## 911 S Coupé 2.0



8/1966-7/1967

1991 ccm, 160/170 PS

## 911 Targa 2.0

12/1966-7/1967



1991 ccm, 130 PS

### 911 S Targa 2.0

12/1966-7/1969



1991 ccm, 160/170 PS

### 911 L Coupé 2.0

8/1967-7/1968



1991 ccm, 130 PS

### 911 L Targa 2.0

8/1967-7/1968



1991 ccm, 130 PS

## 911 T Coupé 2.0



8/1967-7/1969

1991 ccm, 110 PS

## 911 T Targa 2.0



8/1967-7/1969

1991 ccm, 110 PS

## 911 E Coupé 2.0



8/1968-7/1969

1991 ccm, 140 PS

## 911 E Targa 2.0

8/1968-7/1969



1991 ccm, 140 PS

### 911 T Coupé 2.2

8/1969-7/1971



2195 ccm, 125 PS

### 911 T Targa 2.2

8/1969-7/1971



2195 ccm, 125 PS

### 911 E Coupé 2.2

8/1969-7/1971



2195 ccm, 155 PS



## 911 E Targa 2.2



8/1969-7/1971

2195 ccm, 155 PS

## 911 S Coupé 2.2



8/1969-7/1971

2195 ccm, 180 PS

## 911 S Targa 2.2



8/1969-7/1971

2195 ccm, 180 PS

## 911 T Coupé 2.4

8/1971-7/1973



2341 ccm, 130 PS

### 911 T Targa 2.4

8/1971-7/1973



2341 ccm, 130 PS

### 911 E Coupé 2.4

8/1971-7/1973



2341 ccm, 165 PS

### 911 E Targa 2.4

8/1971-7/1973



2341 ccm, 165 PS

## 911 S Coupé 2.4



8/1971-7/1973

2341 ccm, 190 PS

## 911 S Targa 2.4



8/1971-7/1973

2341 ccm, 190 PS

## 911 Carrera RS Coupé 2.7



7/1972-7/1973

2687 ccm, 210 PS

## 911 Coupé 2.7



8/1973-7/1977

2687 ccm, 150/165 PS

### 911 Targa 2.7

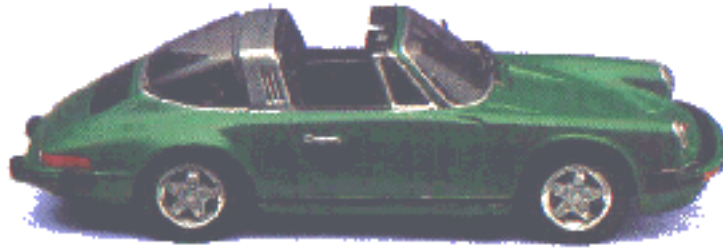

8/1973-7/1977

2687 ccm, 150/165 PS

### 911 S Coupé 2.7



8/1973-7/1977

2687 ccm, 175/210 PS

### 911 S Targa 2.7



8/1973-7/1977

2687 ccm, 175 PS

## 911 Carrera RS Coupé 3.0



8/1973-7/1974

2993 ccm, 230 PS

## 911 Carrera Coupé 2.7



8/1973-7/1975

2687 ccm, 210 PS

## 911 Carrera Targa 2.7



8/1973-7/1975

2687 ccm, 210 PS

## 911 Turbo Coupé 3.0

8/1974-7/1977



2994 ccm, 260 PS

### 911 Carrera Coupé 3.0

8/1975-7/1977



2994 ccm, 200 PS

### 911 Carrera Targa 3.0

8/1975-7/1977



2994 ccm, 200 PS

### 911 SC Coupé 3.0

8/1977-7/1983



2994 ccm, 180/204 PS

## 911 SC Targa 3.0



8/1977-7/1983

2994 ccm, 180/204 PS

## 911 Turbo Coupé



8/1977-7/1989

3299 ccm, 300 PS

## 911 SC Cabrio 3.0



9/1982-7/1983

2994 ccm, 204 PS

## 911 Carrera Cabrio



8/1983-7/1989

3164 ccm, 231 PS

### 911 Carrera Coupé



8/1983-7/1989

3164 ccm, 231 PS

### 911 Carrera Targa

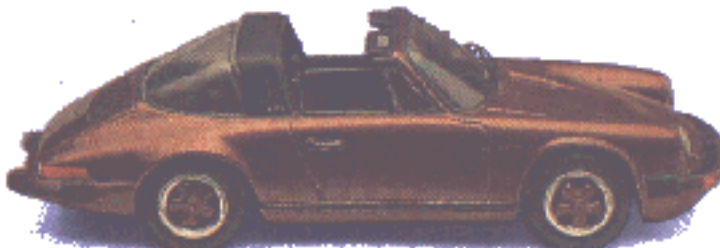

8/1983-7/1989

3164 ccm, 231 PS

### 911 SC RS Coupé



1/1984-12/1984

3000 ccm, 250 PS



## 911 Turbo Coupé Flachbau



8/1986-7/1989

3299 ccm, 300 PS

## 911 Turbo Targa



8/1986-7/1989

3299 ccm, 300 PS

## 911 Turbo Cabrio



8/1986-7/1989

3299 ccm, 300 PS

## 911 Carrera 4 Coupé

8/1988-./.....



3600 ccm, 250 PS

### 911 Carrera 2 Coupé

8/1989-./.....



3600 ccm, 250 PS

### 911 Carrera 2 Targa

8/1989-./.....



3600 ccm, 250 PS

### 911 Carrera 4 Targa

8/1989-./.....

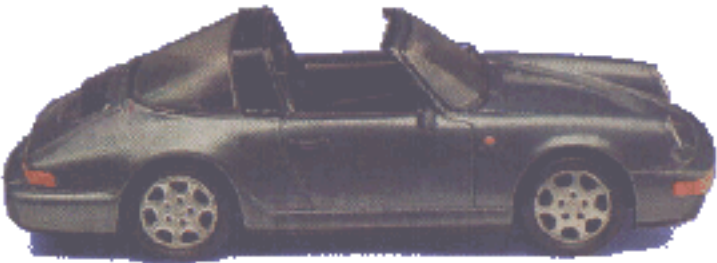

3600 ccm, 250 PS

## 911 Carrera 2 Cabrio



8/1989-./.....

3600 ccm, 250 PS

## 911 Carrera 4 Cabrio



8/1989-./.....

3600 ccm, 250 PS

## 911 Carrera 2 Cup



3/1990-./.....

3600 ccm, 250/270 PS

## 911 Turbo Coupé

8/1990-12/1992



3299 ccm, 320 PS

### 911 Carrera RS Coupé

11/1991-./.....



3600 ccm, 260 PS

### 911 Speedster

10/1992-./.....

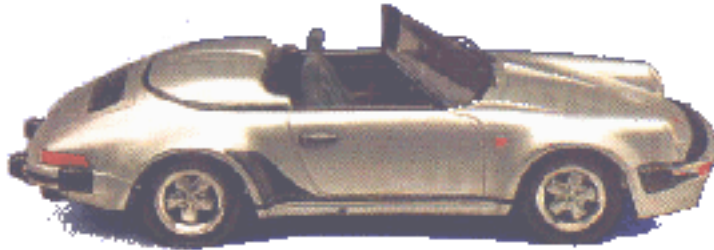

3600 ccm, 250 PS

### 911 Turbo Coupé 3.6

1/1993-./.....



3600 ccm, 360 PS

The actual wheel offset of all 964s, except some special versions remained 52.3mm.

# Approved Wheels and Tyres

The following wheels are those which are approved for use on the models mentioned as supplied in Porsche Factory documentation.

## 1989 and 1990 Carrera 2 and 4 Approved Wheels

### Cast Aluminium Design 90



6JX16	55mm	p/no	964 362 114 01
7JX16	52.3mm	p/no	964 362 112 01
8JX16	52.3mm	p/no	964 362 116 01
9JX16	52.3mm	p/no	928 362 118 02

### Forged Aluminium

6JX16	52.3mm	p/no	944 362 113 00
52.3mm			944 362 113 01
8JX16	52.3mm		928 362 117 00
52.3mm			928 362 117 01

## Approved Summer Tyres (manufactured to Porsche specifications)

### 16 inch only

Dunlop SP Sport D 40 ZR N0 (1989 only)

Goodyear Eagle VR or ZR N0 (1989 only)

BF Goodrich Comp T/A N0

Bridgestone RE71 N1

Yokohama A008P N0

## Approved Winter Tyres (approved only no N ratings)

16 inch only for 1989 and 1990

Pirelli Winter 190 (1989 only)

Dunlop SP Winter Sport (1989 only)

Bridgestone WT 04 for all winter driving conditions

Continental TS 750 for all winter driving conditions

Goodyear Eagle GW for frequent autobahn driving in winter

Michelin X M+S 330 for all winter driving conditions

Semperit Direction Grip only to be used in heavy snow regions

## 1991 to 1994 All Carreras Approved Wheels

Note: Standard wheels for the narrow body 911 Carrera 2, 4 and Speedster remained the 16 inch wheel. The RS, RSA, Turbolooks and standard Turbos were fitted 17 inch wheels and the Turbo S, S2 and Turbo 3.6 were fitted with 18 inch wheels.

### Cast Aluminium Design 90

6JX16	55mm	p/no	964 362 114 01
7JX16	52.3mm	p/no	964 362 112 01
8JX16	52.3mm	p/no	964 362 116 01
9JX16	52.3mm	p/no	928 362 118 02

### Forged Aluminium

6JX16	52mm	p/no	944 362 112 00
6JX16	52.3mm	p/no	944 362 113 00
	52.3mm	p/no	944 362 113 01
8JX16	52mm	p/no	944 362 116 00
8JX16	52.3mm		928 362 117 00
	52.3mm		928 362 117 01

### Cup Design 92



6JX16	52mm	p/no	944 362 112 00
8JX16	52mm	p/no	944 362 116 00
7JX17	55mm	p/no	965 362 124 00/01
7.5JX17	55mm	p/no	965 362 124 15
8JX17	55mm	p/no	965 362 126 00/01
9JX17	55mm	p/no	965 362 128 00
9JX17	55mm	p/no	965 362 128 10

9.5JX17      68mm      p/no      965 362 128 05

### Cup Design 93



7JX17	55mm	p/no	993 362 124 00
8JX17	52mm	p/no	993 362 126 00

### Speedline for Porsche Cup Design Modular



18 Inch Wheels Approved for the Turbo S, Turbo 3.6 and 3.8RS

8JX18	52mm	
9JX18	48mm	Front for RS 3.8 only
10JX18	61mm	
11JX18	5mm	Rear for RS 3.8 only

17 Inch Wheels offered as an option on the RS 3.8 only

8JX17	52mm	Front
9JX17	64mm	Rear
11JX17	55mm	Rear

43mm spacers are required for the rear wheels.

### Approved Summer Tyres (manufactured to Porsche specifications)

16 inch only

Bridgestone Expedia S-01 N0

Michelin MXXX 3 N0

Pirelli P700-Z N0

Yokohama A-008P N0

## **Approved Summer Tyres (manufactured to Porsche specifications)**

### **17 inch only**

Bridgestone Expedia S-01 N0

Michelin MXXX 3 N0

Pirelli P700-Z N0

Yokohama A-008P N0

### **18 inch only for approved for the RS 3.8**

Dunlop 8000SP N0 235/40ZR18 front

Dunlop 8000SP N0 285/35ZR18 rear

## **Approved Winter Tyres (approved only no N ratings)**

### **16 Inch only 1991-1994**

Bridgestone WT 04 for all winter driving conditions

Continental TS 750 for all winter driving conditions

Goodyear Eagle GW for frequent autobahn driving in winter

Michelin X M+S 330 for all winter driving conditions

Semperit Direction Grip only to be used in heavy snow regions

### **17 inch only 1991-1994**

Bridgestone WT 05 for frequent autobahn driving in winter

Continental TS 750 for all winter driving conditions

Dunlop Winter Sport M2 for all winter driving conditions

Semperit Direction Grip only to be used in heavy snow regions

Toyo 920 for all winter driving conditions



# Complete 964

## Drivetrain

### GENERAL-

The G50 gearbox that had been recently introduced (1987) on the Carrera 3.2 was also utilised on the 964. The gearbox and associated clutch mechanisms were a far improved unit when compared with the gearboxes utilised on the earlier Carrera 3.2's.

Perhaps the most significant change was the addition of a dual mass flywheel (produced by Freudenberg) in 1990 to both the Carrera 4 and 2, that was in theory supposed to smooth out torque output when pulling at low engine speeds hence removing gear chatter from the gearbox. Unfortunately, the long term viability of this dual mass flywheel proved less than reliable, and was subsequently replaced in the Carrera 2 by a new flywheel produced by LUK in 1993 (such flywheel can be retrofitted to earlier Carrera 2's with ease). However, due to different torsional frequencies, the Carrera 4 maintained the original Freudenberg dual mass unit to eliminate unnecessary vibration.

### THE 4 WHEEL DRIVETRAIN-

The four wheel drive mechanism of the Carrera 4 also utilised a variant of the G50 gearbox (G64), although this obviously had to be significantly adapted to drive the front wheels of the Carrera 4. The front differential housing was linked to the gearbox via a large diameter tube that (through the gearbox's hollow secondary shaft) connected to an epicyclic differential at the front of the gearbox. From there, the drive moved to the rear differential via a shaft passing through the hollow secondary shaft. The front/rear torque split was maintained at 31/69% through the central differential. This central differential was in turn controlled by a "multiplace clutch" that could automatically actuate whenever wheel spin was identified by the ABS system. The clutch would then provide excess



Note the left dial which is utilised to lock the 4 wheel drive mechanism on the C4 (the C2 has only one dial for the manual wing control).



The spiritual ancestor to the Carrera 4, the awesome Porsche 959.



Note the tiptronic gearshift in this 964 Carrera 2 coupe.

torque to the axle with the "better grip". A similar electronically controlled rear differential would act as a normal differential (split drive between left and right rear wheel) as well as intervene whenever the accelerator was released while cornering, in order to minimise the accelerator pedal off oversteer tendency of the 911. As a result, the Carrera 4 was a far safer car for the inexperienced driver when compared with the Carrera 2- which was however deemed to be the better experienced drivers car. Indeed if an experienced driver were to take a Carrera 4 and a Carrera 2 onto a race track, the Carrera 2 would almost always be faster. The converse is obviously true of an inexperienced driver, who could find himself in a significant amount of trouble without the aid of the four wheel drive.

### TIPTRONIC-

In 1990, the 964 Carrera 2 was offered with Porsche's first fully automatic transmission (the Tiptronic). The transmission also permitted the manual selection of gears up to a point- if and when a gear selection was thought to be harmful by the electronic system, the transmission would not allow such a shift. For example, the transmission would shift up when maximum permissible engine revs had been reached, or move automatically down when the engine speed had reached a speed incompatible with the gear selected. An interesting point of note was that the transmission would always select 2nd gear for a start, unless a sprint was required, at which point the driver could select 1st gear. The fully automatic mode was achieved by shifting the gear selector into the "D" position on the gear shift plate. Conversely, to select manual mode, the gear selector would have to be shifted to the right into the short lane with "+" and "-" selectors. From this gate, the four different gears could be selected "manually"- forward pushes would select higher gears, pulling back the lever would select a lower gear. The Tiptronic system, whilst extremely competent, remained a weak link in the Carrera 2 given that there were only four gears on tap. Performance obviously suffered with 100kmh being reached only after 6.6 seconds, as opposed to 5.5 seconds for a manual Carrera 2.



Tiptronic equipped cars had the details of gear engagement on the rev limiter.

Indeed, if five gears had been offered, it is most certain that an enthusiast would be far more likely to consider a Tiptronic equipped car for spirited driving. As was, the Tiptronic gearbox made sense for a large number of city dwelling 911 owners, who all too frequently got stuck in traffic. However, there were exceptional 3rd party supplied alternatives, such as the RUF E. K. S. system (to be described under Modifications).

# Complete 964

## Brakes

The 964 Carrera 4 and Carrera 2 maintained different braking systems out of necessity. The four wheel drive mechanism in the Carrera 4 was linked via the same hydraulic pump system to the brakes system which incorporated a Bosch ABS anti-lock system. Note that the four wheel drive mechanism and brake system functioned together in order to control such vices as lift off oversteer in the Carrera 4 model (a more detailed write up on this particular aspect is in the process of being written up).

Basically, the two front wheels were individually controlled by two brake sensors of the ABS system whilst the rear wheels operated such that if one wheel began to lock, both wheels would be released at the same time thus alleviating any instability.

Discs on the Carrera 4 comprised four vented discs (298/299mm diameter, 28mm thick front and 24mm thick rear) controlled by four piston calipers all round. In it's time, it was possibly one of the best braking systems available on any production car.

By comparison, the Carrera 2 operated on a more conventional vacuum servo that was located where the front differential in the Carrera 4 was situated. Furthermore, prior to 1992, the Carrera 2 utilised two piston rear calipers (which were replaced by the four piston Carrera 4 calipers only in 1992).

For the Turbo model, brakes were further uprated with 322mm diameter/32mm thick front discs and 299mm diameter/28mm thick rear discs. Larger calipers were also utilised to hold larger brake pads. All this amounted to a phenomenal braking performance of 35.6 meters from a speed of 100kph. Note that these brakes were easily retrofitted to both the Carrera 4 and 2 models.



Original calipers on 964  
Carrera 4

# Complete 96 4

## Wheels

The 1989 964 saw the demise of the famous Fuchs alloys, wheels that had been synonymous with the 911 up to that point.

The offset of the Fuchs alloys were completely incompatible with the newly designed four wheel drive mechanism and the ABS brakes that had been installed on the 964. As such, a totally redesigned rim was offered- the Design 90 alloy. The offset of this new rim was 52mm and the tires moved to 205/55ZR's up front, and 225/50ZR's rear.

In 1992, the Design 90 was replaced by five spoke cast aluminium rims (Cup Style). These were made available in 16" to 18" sizes with widths from 6" to 10". Note that the rim sizes above 16" were actually only made available in 1992, after the use of such rims on the 965 Turbo (17" rims were 9J front wearing 205/50ZR's and 255/40ZR's rear).

Wheel specs between the Carrera 2 and Carrera 4 models were identical for the front and rear wheels (even though the front suspension had to incorporate the 4 wheel drive system for the Carrera 4) ie:

- Design 90 and Cup Style front: 6J 16 52mm on Carrera 2 & 4 wearing 205/55ZR16 (1990-1993)
- Design 90 and Cup Style rear: 8J 16 52mm on Carrera 2 & 4 wearing 225/50ZR16 (1990-1993)

For the 17" rims, the following details were applicable as follows (incredibly confusing):

- Cup wheels front: 8J 17 55mm on Carrera 2 Cup wearing 235/45ZR17 (1990)
- Cup wheels rear: 9.5J 17 55mm on Carrera 2 Cup wearing 255/40ZR17 (1990)
- Cup wheels front: 7J 17 55mm on Turbo (1991-1992), Turbo look (1992 & 1994 C4 special) and RS America (1992) wearing 205/50ZR17



The Design 90 rim that replaced the Fuchs rims.



Note the Cup Design 16" rims that replaced the Design 90 rims in 1992.



The ever popular 17" cup/turbo 1 style rims. Note that the RS used an extremely lightweight, forged version of these rims.

- Cup wheels rear: 8J 17 52mm on RS America (1992) and C4 special Turbo look (1994) wearing 255/40ZR17 for the RS America and 225/45R17 for the C4 special Turbo look
- Cup wheels rear: 9J 17 55mm on Turbo (1991-1992) and Turbo look (1992) wearing 255/40ZR17
- Cup wheels front: 7.5J 17 55mm on RS wearing 205/50ZR17 (1992)
- Cup wheels rear: 9J 17 55mm on RS wearing 255/40ZR17 (1992)

18" rims only saw the light of day on the Turbo S in 1992 and the Turbo in 1993.

Since then, a large number of aftermarket copies of the 17" and 18" original Porsche rims have been made available, and it is worth noting that later model rims such as those from the 996 can actually fit onto the 964 with a minimum of problems [[also see Modifications-Wheels](#)].

# Complete 964

## Body

It was determined that the general shape of the new 964 would retain the "essential character" of the 911, obtaining near zero lift in the front and rear without the aid of the whale tail or other additions that would break the classic lines of the 911 (the whale tail, whilst performing its function extremely well, was largely criticised in it's time for its excessively obvious lines). This was essentially obtained via the use of a fully covered floor pan, and an electrically operated rear wing that would raise automatically at speeds above 80km/h, lowering again only when speeds fell below 15 km/h.

The most significant changes to the 964's exterior were the replacement of the previous front and rear impact bumpers with single piece bumpers manufactured of deformable, moulded thermoplastic material (technically referred to as Bexloy APV 573).

At the same time, the old black rubber strips that lined the side of the body attaching the front and rear wheel arches was replaced by a two piece side skirt that was bolted on to the body shell. Given a move away from the torsion bar suspension system, the torsion bar holes just in front of the rear wheel arches were thus made obsolete.

Additionally, the rear tail lights were re-designed into a single colour (red) light with an angled profile (moving outwards toward the base). This was purely an aesthetics issue as the lights are not claimed to improve aerodynamics in any way. Also during the life of the 964, the side mirrors were changed from the square design carried over from the previous Carrera 3.2 to "teardrop" designs in 1992.

The sun roof front wind blocker was also enlarged on the 964 to provide better protection from wind intrusion when the sun roof was left open at high speed (unfortunately, wind noise still remained a significant problem!).

Other details aimed at improving the aerodynamics and functionality of the body



The electric rear wing with automatic raising and lowering allows the 964 to retain the classic 911 lines whilst still maintaining required aerodynamics.



Rear roof lowered closer to rear window.



Rear tail light details

included the following-

- The gap between the roofline and the rear window were reduced (the "air vents" at the rear of the roof in the 3.2 were essentially removed- these air vents provided an escape route for cabin air. Air exit points were as a result moved to underneath the wheel arches).
- The front wind shield was glued into a rubber seal with a significantly reduced profile.
- The side windows were less recessed.
- The drip rails were reduced in size where they came close to the wind shield.
- The front oil cooler and air conditioner condenser were place in either wheel arch in front of the front wheel at an angle that benefited increased air flow via newly placed ducts under the chassis near the front bumper.



Rear wiper mount point changed from external mount on rear engine cover to mount through rear windscreen.



New tear drop design mirrors introduced in 1992.



# Complete 964

# Suspension

Whilst the basic theory behind the 964 suspension is similar to the preceding Carrera 3.2- Macpherson/rigid lower front arms and semi trailing arms in the rear, the actual execution of the suspension was significantly different. This could be attributed to two key changes in the 964-

- The requirement to accommodate the new drive gear (differential & drive shafts) on the four wheel drive model of the 964.
- The utilisation of the Borg Warner transmission [[see also Drive train](#)] over the old Porsche synchromesh (actually this change was already catered for to some degree in the 1988 model Carrera 3.2 which already utilised the G50 gearbox).

The new four wheel drive mechanism essentially restricted the ability for the 964 to utilise the traditional torsion bar type suspension in the front, whilst the G50 gearbox, which was longer than the previous 915 gearbox required that the rear torsion bars be "broken" or relocated to house the longer gearbox.

This resulted in coil over type shocks being utilised on lower cast aluminium A arms. The key advantage of this was that the old torsion bars utilised in the 3.2 did not allow for fore and aft movement of the front suspension arms, which in turn translated into an unsettled ride over sharp bumps. The coils, conversely, permitted the Porsche engineers to build in a degree of fore/aft compliance of the suspension arms, which in turn enabled the front wheels of the 964 to move backwards slightly when hitting a sharp bump. This would in turn reduce the impact and the associated unsettling behaviour that affected the cars stability. At the same time, negative scrub radius was incorporated in the front suspension geometry (the 3.2 had positive scrub). Together with the assistance of the ABS, this gave a degree of steering correction when the front wheels began to slip. The four wheel drive and two wheel drive cars had identical suspension units.

The rear suspension was also designed to combat a natural tendency of trailing arms to toe out whenever lateral braking forces were applied. However, given the trailing arm design, any clever attempts by the Porsche engineers to completely iron out all the bugs of the chassis would not occur until the complete redesign of the suspension system with the arrival of the 993.

In spite of the limitations, it was still determined that the 964 was an easier car to handle than the previous incarnations of the 911. Indeed, the Carrera 4, whilst suffering from noticeable understeer when compared to its two wheel drive brother, was deemed to be an extremely competent driving machine for the less experienced driver. This was partly attributable to the "significant" drive to the front wheels. By comparison, the decreased understeer of the Carrera 2, resulted in a car that was considered a more



Front strut detail through wheel arch (non standard Techart spring)



Rear coil over detail (non original Tecahrt springs and Bilstein dampers)

entertaining ride for the experienced driver.

There has been some confusion over the key differences between the Carrera 2 and Carrera 4 suspension (though there have been no arguments over the fact that the 965 Turbo suspension was significantly different!).

Based on various reference material on hand (Porsche 911- Forever Young by Tobias Aichele and Original Porsche 911 by Peter Morgan), and my discussions with various Porsche mechanics, it would appear that the suspension of the 964 Carrera 2 and 4 are basically identical except for the absence of drive shafts on the Carrera 2.

Two key differences in the various models are as follows-

- The usage of different thickness anti roll bars on the various cars. A prime example is the fact that the Tiptronic models utilised 19mm anti roll bars on the rear (20mm on the front), whilst the comparable manual Carrera 2 and Carrera 4 utilised 20mm anti roll bars all round.
- The incorporation of steering stops to allow the use of the wider and generally larger 17" cup wheels in 1992 (easily retrofitted to earlier 964s). This followed on from the 1991 introduction of 17" rims for the Turbo model.

Another important production change during the life of the 964 involved the rear shocks and springs (and the associated mounting points on the chassis) which were changed in 1991 (shorter springs and dampers) to provide more space for roof storage of the convertible model.

From 1991 a sport suspension option was also provided for both the Carrera 4 and 2 models (this was not easily retrofitted to pre 1991 models given the completely different mounting points). The package comprised four revalved dampers (stiffer Boge units), a thicker front antisway bar (up to 22mm from 20mm) and significantly stiffer rear springs. The Turbo models suspension was further upgraded to include wider suspension arms, even stiffer springs and a combination 21mm front/22mm rear antisway bars. Overall ride height was 20mm lower than the standard 964 Carrera 2 or 4 models.

# Complete 96 4

## Engine

Both the Carrera 4 and 2 engines (M64/01) were increased in capacity to 3600cc (up from the previous models 3200cc engines).

Whilst the bore centres were the same as the original 2000cc engine, increased capacity was achieved by enlarging the bores from 95mm to 100mm and the associated stroke from 74.4mm to 76.4mm. This longer stroke naturally required a new crank shaft, which despite a longer throw, was actually 2.2kg lighter than its predecessor. Small air shields were also incorporated onto the crank case shell, thus helping to direct cooling air to the base of the cylinders.

Additional attempts to keep the cylinder heads cooler, resulted in the cylinder heads utilising ceramic port liners (this insulated the cylinder heads from the hot exhaust gases that were in close proximity).

A new 12 blade cooling fan was utilised, and this was driven at the same speed as the 959's- at a claimed ratio of 1.6:1 which resulted in a fan speed 4.2% slower than that of the 3.2 engine.

For the first time, a twin spark ignition system was utilised (with double distributors- the secondary distributor being driven by the first distributor via a small tooth belt mechanism. This allowed the ignition timing to be retarded by 6 degrees over the 3.2 engine, which in turn permitted the compression ratio to be increased to 11.3:1 despite a decrease to 95 RON fuel. The overall impact- an engine with faster combustion and increased engine efficiency.

The engine oil cooler mounted in the engine bay that had been utilised on previous 911's was replaced by an enlarged oil radiator cooler in the front right fender.

Final specs of the engine may be summarised as follows-

- 250bhp DIN at 6,100rpm



The 3.6 engine. Note that the air box can be updated to the 993 air box and air flow system for substantial power gains.



Above engine has Cup bypass pipe replacing the original primary muffler- a common upgrade.



- 310Nm torque at 4,800rpm
- Full weight of vehicle 1,430kg vs Carrera 3.2 at 1,210kg
- 0-100kph in 5.5 seconds
- 0-160kph in 12.9 seconds (Carrera 2), 13.2 seconds (Carrera 4)
- 0-200kph in 21 seconds (Carrera 2), 22.1 seconds (Carrera 4)
- Distance of 1km from standing start 25 seconds

Please note that a discussion on the Turbo engines (3.3 and 3.6) are in development and will hopefully be ready soon.

# Complete 96 4

## Interior

For a seasoned 911 driver, entering the cabin of the 964 would not present any significant surprises. The dash board remained largely unchanged, with the exception being in the details. The instrumentation for the first time included a large array of warning systems pertaining to all areas of the vehicle (automatic wing malfunction, fan belt, brakes, ABS failure etc- a total of 13 warning lights) which were all located on the rev counter and clock (as opposed to the Carrera 3.2, where the brake pad wear indicator etc was near the air conditioning controls. The instrumentation was also now backlit, with the oil pressure and temperature needles now pivoting from external points rather than from behind the main instrumentation cluster.

The air con control system was also finally updated from the "slide" control mechanisms of years gone by to the 944 climate control unit.

Perhaps the most significant change in the 964 was the introduction of a high centre console for the first time in a 911. In front of the gear shift lay two switches- one for rear wing manual override (only from 1990 onwards) and four wheel drive locking. The reasoning behind the high centre console was simple- the high console concealed the four wheel drive system of the Carrera 4.

Also, for right hand drive models, the front hatch release lever was finally moved to the drivers side (unfortunately the same cannot be said of the fuel filler cap or the engine compartment opening lever which continued to remain on the left hand side).

From 1990, an on board computer was also supplied as an option to the 964, as were passenger airbags for certain markets. In 1991 an interior light time delay mechanism was also introduced (this could also be readily retrofitted to pre 1991 models).

Front seats were largely unchanged from the previous fully electrical units that permitted a large array of adjustments at the press of a button. Rear seats remained the same until 1991



New centre console extending the full length of the cabin added a modern touch to an otherwise excessively spartan interior.



Note the entry points of the rear seat belts.



The air con control mechanism lifted from the 944. Note the temperature dial on the far right of the screen which now has an external pivot point.

when the rear seat release buttons were moved from the inconvenient mount points to the rear tops of the seats. Rear seat belt mounting positions were revised to under the rear parcel shelf.

1993 was the first year that drivers side airbags were included in right hand drive models.



The front seat control mechanisms.

# Complete 964

## 4

## Floor Plan

Given that the 911 body shell and floor plan design had essentially been maintained for the better part of a quarter of a century, serious re-engineering of the platform would be required in order to accommodate an all new four wheel drive mechanism.

As a result, the 964 was essentially 87% new when compared to its predecessor, the Carrera 3.2. This was hard to believe given that the 964 shared the same familiar shape as the 3.2, and general body changes were minimal.

However, as was so often the case with Porsche, the changes were not obvious to the eye, but instead lurked beneath the metal work.

As with previous 911's, the chassis base structure (and the body shell) was made of hot zinc-dipped steel. The effect of this was that the sheet metal maintained a considerably longer lifespan when compared to untreated steel. Of course, if the zinc coating was broken, the steel would rust readily, and hence it should be remembered that you can still find rust on 964's.

The front luggage compartment was redesigned to accommodate the new Carrera 4's drive train and differential. In line with this, the fuel tank was required to be reduced from 85 litres to 77 litres. The air conditioning unit was also moved forward, into the luggage compartment, where before it was located in the passengers foot well. This resulted in increased space for the front passenger.

Aerodynamically, the underside of the 964 was enclosed with floor pans running the entire length of the chassis from the front bumper all the way to the back of the automobile. Air flow was as a result controlled through the automobile, even to the extent of directing engine cooling air in from an air duct in the floor pan horizontally and out the rear of the automobile (compared with air being forced in vertically in the 3.2). This has been said to reduce rear lift in the 964.

It has however been found that the pan covering the engine compartment has in the



Rear engine pan with air duct whilst providing aerodynamics, can be removed for better engine cooling with little effect on aerodynamics.



Front luggage compartment revised to accommodate four wheel drive transmission.

past not allowed sufficient cooling to the engine bay, thus resulting in excessive wear to the engine (in simple terms). As such the most common modification done to 964's today is to remove the rear engine pan (a simple process of unbolting the pan). Overall aerodynamic impact has been shown to be minimal.



# Complete 964

## Coupe

### General :

First introduced at the end of 1988, in the form of the Carrera 4 and subsequently made available as the Carrera 2 from 1990, the coupe models were made available with or without sun roofs. The enthusiast has always felt the coupe to be the purest form of expression for the 911.

Indeed, the coupe version (and particularly those without such niceties as the sunroof) provided significantly more rigid platforms which translated to a better handling vehicle with less flex. It was for this reason that drivers utilising their car's for competitive purposes generally preferred coupe models over the other 964 variants.

Furthermore, it should be remembered that a lower drag coefficient equated to increased aerodynamics. As such, the narrow body version was viewed by some as more desirable than a wide body equivalent (all other factors being equal).

### Special Editions:

In 1993, a wide body celebration model was introduced (chassis was only available as the Carrera 4) celebrating 30 years of continuous 911 production. It should be noted that this model was not a full Turbo look conversion with brakes and running gear- indeed only the wide front and rear fenders were utilised, with the brakes and suspension all coming straight from the standard Carrera 4. A total of 911 of these cars were manufactured (it is not known if any came to Singapore).

Perhaps one of the most interesting derivatives of the standard coupe was a lightweight (non street legal) version of the Carrera 4. At the insistence of Jurgen Barth, 20 examples of a stripped out and enhanced Carrera 4 were produced. The car, weighing in at 360kg less than the standard car (thanks to a stripped out interior, aluminium doors and front lid, a fixed rear spoiler, plastic side windows and lightweight glass front/rear windows and no



Here can be seen a 964 Carrera 4 coupe (1989 example with updated side mirrors). Note that the rear badging on this particular example has been removed, and the original rims have been replaced with RUF 17" rims.



Another clean example of the 964 coupe, this one with the original 1992 rims that replaced the Design 90 rims.

ABS) also had a unique transmission that allowed for manual control of drive to the front and rear wheels (not unlike the RUF 6 speed gearbox available for the 964 which allowed one to change the characteristics of the car from an under steerer all the way to an over steering car). This gearbox was configured with acceleration in mind (the top speed being limited to just over 200km/h whilst 100kmh could be reached consistently in under 5 seconds). Power was capped at 265hp (minor modifications being a similar exhaust to the Cup Cars), with power being transmitted through a single disc competition clutch.



Lightweight C4 competition car (see text).

# Complete 96 4

## Speedster

The Speedster was introduced in 1993 as a light weight stripped out racer. With a low roof line, no rear seats, and minimalist cabin, the Speedster was indeed the enthusiasts driving machine. Everything done in the Speedster felt faster than when done in a comparable coupe. Indeed, half of this experience surely came from increased wind noise, enhanced engine "noise" intrusion and a general feeling of being closer to the road (thanks to those lovely one piece Recaro's with colour coded backings and the standard 17" Cup rims- usually also colour coded to the body).

The Speedster was made available only as a Carrera 2, with either a manual 5 speed gearbox or an optional tiptronic transmission. Note that the Singapore market only provided tiptronic Speedsters.

A low front screen that was not removable (unlike the earlier Speedsters) resulted in better tolerances for roof seals which in turn minimised leaks.

Raising and lowering the roof, whilst relatively easy, were definitely more complicated than the raising and lowering of the fully automated convertible roof. This was definitely not a job to be entertained under emergency weather conditions (a minimum time of around 2 minutes to perform any roof raising or lowering and closer to 5 minutes is to be expected).

Unlike the 1989 Carrera 3.2 model, perhaps dissappointingly, the 964 Speedster was never made available in a wide body version (although Strosek made an absolutely beautiful wide body conversion for this car).



Rare silver speedster. Note that the seats are not the original colour coded backed Recaro items, but appear to be the comfort option. Rims are also not original on this example.

# Complete 96 4

## Targa

For those who desired the wind in the hair experience with the safety of a coupe, the Targa was always an obvious choice.

First introduced together with the Cabriolet in 1990, the Targa had a built in roll over hoop for safety, with a detachable centre roof piece. It is worth noting that the roof was never entirely water proof, although any leakage if any was minimal. The chassis was reinforced to take account of the "missing" roof, and the roll over hoop added some torsional rigidity to the rear of the chassis.

The Targa was available in both the Carrera 4 and Carrera 2 format, and was manufactured up until 1993.



Standard 1992 Targa with updated "cup design" 16" rims that replaced the Design 90 rims, and the turbo style side mirrors.

# Complete 964

# Cabriolet

The cabriolet was made available in 1990 for those who needed the ultimate wind in the hair experience.

Much like the Targa, the cabriolet was designed with significant reinforcements to the chassis in order to take account of the lack of roof. This resulted in a convertible with no shake, flex, or rattle normally associated with a convertible.

Unfortunately, this also translated to a weight increase which marginally compromised the car's all out performance.

The fully electrically operated roof was first seen as an option in 1987, only becoming standard equipment in 1989. The automatic roof latching mechanism is still exceptionally easy to operate by today's standards. With the key in the auxiliary position, a press of the top actuator (located under the instrument cluster) until the roof is fully folded is all that is required.

The Cabriolet was available in both the Carrera 4 and Carrera 2 format, and was also manufactured as a Turbo Wide Body look in 1992 (also available as Carrera 2 and 4).



Standard narrow body 964 cabriolet.



Wide body cabriolet option.

# Complete 964

# Turbo

## 3.3 Turbo

The 964 Turbo was first introduced in March 1990 (1991 model year), when the 3.3 version was produced based on the Carrera 2 chassis.

The engine utilised in this vehicle was the old 3.3 engine from the previous 1989 Turbo, modified to extract additional power. Performance quoted was 320bhp at 5750rpm and 450Nm torque at 4500rpm. Due to the remapped Motronic system, the car was not only more powerful, but provided improved fuel efficiency and emissions.

## 3.6 Turbo

The 3.6 Turbo was introduced in October 1992. The engine, a development of the 3.6 Carrera 4 and 2 unit, was utilised.

Compared with the 3.3 unit, the 3.6's compression ratio was increased from 7.0:1 to 7.5:1. Power rose to 360bhp and 520Nm, with unchanged fuel consumption.

Unfortunately, the infamous turbo lag still prevailed in this model, although less noticeable than when compared against earlier models.

Note that this automobile was also produced in a very limited run of flat noses (mechanicals identical to standard 3.6 Turbo).

## Turbo S

The rarest of the 964 Turbos, only 80 of these were made. It was recognised that the 3.3 Turbo was not all that it could have been, and Porsche had determined that a variant of the 3.3 Turbo be produced pending the final introduction of the 3.6 Turbo. Power of the Turbo S was increased to 381bhp at 6000rpm, with maximum torque of 490Nm being reached at 4800rpm.

In order to enhance performance, it was decided that the car would be designed in the same mold as the Carrera 2 RS, ie: lightweight with increased power. To this end, the Turbo S had a stripped out interior (no rear seats, bucket seats at the front, fabric door pulls and mechanical winding windows). Additionally, the doors, the rear engine lid and the front luggage compartment were all made out of composite materials. All this added up to a Turbo

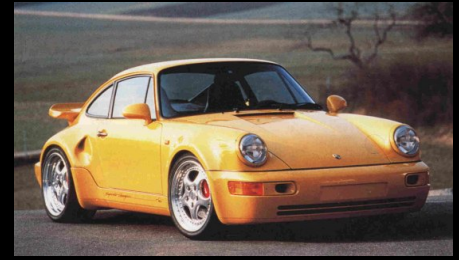

Press shot of 964 Turbo S. Note the front air ducts providing cooling to the front discs and the side engine air vents.



Standard 3.6 Turbo. Note the 3.6 script aside the Turbo signage. Note the large flared front and rear wheel arches when compared to a standard 964 coupe.

More pictures coming in the near future. Stay tuned.

that weighed 190kg less than the standard 3.3 whilst producing higher power- a formidable combination that allowed the car to reach 100kmh in under 4.7 seconds. Note that the key external differentiating feature are air vents at each rear fender just in front of the rear wheel that provided much needed additional air flow into the motor.

# Complete 964

RS

## RS 3.6

The RS was a driving machine with minimal concessions provided for comfort.

Upated suspension, seam welded chassis, lack of power steering, rechipped/higher output engine, larger rims, rolled wheel arches, turbo brakes up front, Cup brakes in the rear, revised gearbox and no rear seats all added up to an incredible driving machine.

Further weight saving measures included the removal of a significant number of the electrical components such as the seat motors, electrically operated side view mirrors, lack of power windows, removal of superfluous door fittings such as side pockets, door handles etc, lack of gas struts to hold up bonnet and boot, no undercoating and a reduction in sound proofing material.

Perhaps not as drastic an automobile as the 993 version of the RS, the 964 3.6 RS was non the less an impressive driving machine. A constant willingness to rev itself to death, stiff as rock suspension and fantastic handling with strong brakes all added up to an adrenalin producing sled (if not a little tricky at the limit).

Most notable differences included a bulging rear tail, lowered suspension and 17" Cup rims.

Performance was 260bhp at 6100rpm and 325Nm at 4800rpm. A total of 2,051 cars were built.

## RS 3.8

In 1993, a more extreme RS was introduced. The RS 3.8 was an extremely limited run (100 total?) vehicle produced on a Turbo Wide Body chassis with a non turbo charged engine of





3746cc. The car maintained phenomenal performance with 300bhp at 6500rpm and a maximum torque of 360Nm at 5250rpm.

Power was transmitted through the 18" Speedline rims wearing massive 235/40ZR tyres up front and 285/35ZR tyres in the rear.

Performance figures quoted on the 3.8 were 0-100kph in 4.9 seconds, and a top speed of 274kph.

### RS America

The US markets did not have the European RS (regulations did not permit the vehicle given the thinner side glass, lack of side intrusion bars etc that were all weight saving measures). To quench the thirst of the enthusiast, the RS America was manufactured. For all intents and purposes, the car was a stripped down Carrera 2 (no aircon, no rear seats etc), with a fixed rear wing and sports suspension pack. The engine etc was not updated.

Such models were actually cheaper than the standard Carrera 2's on offer at the time, although the driving experience was less diluted.

These should not be confused with the extremely rare Carrera Cup 964's brought into the US specially for the aborted Cup races- these cars carry significant premiums over almost any 964 due to their extreme rarity and rather strange history [[CLICK HERE FOR MORE INFO ON THE CUP CAR](#)].



Production RS in maritime blue and in racing livery

# Complete 964

## Suspension

### General-

The standard 964 comes with a relatively compliant suspension and springs to cater more for a Grand Tourer type market than an all out driving enthusiast. To this end, the easiest modification would be to replace the full suspension set up on the 964 (coils and dampers) with the Porsche Sports Option (assuming your car is a post 1991 model). Of course, this is not cheap, and there are alternatives.

Perhaps the three best known alternatives are provided by RUF, Techart and H&R.

### RUF-

The RUF package is the most interesting in that it includes dampers (Bilstein re-valved units), progressive coil over springs in a strange shade of army green (for the fashion conscious) and anti sway bars front and rear. Handling is excellent, and the car is only marginally lowered, thus maintaining practicality. The annoying tendency of excessive body roll in the 964 is completely done away with, and the car appears to steer into corners more readily (ie: the general under steering tendency of the 964 is reduced). A full test of the suspension package will be performed at a later stage. Pricing stands at around SGD6,000 without installation.

### Techart-

Techart (an official supplier of modified parts to Porsche for some time), produces a suspension package that also consists of Bilstein damper units (re-valved to Techart specs), and 4 progressive coil over springs (in white, if you happen to be interested) that lower the car approximately 1-1.5". We have not yet had a chance to test the full Techart suspension, and as a result cannot comment on its characteristics. Pricing stands at SGD6,500 installed.

### H&R-



Front suspension arms tied together with a Techart front strut bar.

The final suspension package offered is by H&R and like the Techart kit comes with dampers and progressive rate springs. We have yet to test this kit, at which time a full analysis will be performed. Pricing stands at around USD2,900 without installation.

### The Authors Car-

The Author's car currently utilises Techart progressive rate springs (front and rear) mounted on Bilstein shocks in the rear. The front continues to utilise the stock Boge shocks providing a slightly softer front end. The front shocks are tied together by a Techart front strut bar (to stiffen the front struts, minimising flex and theoretically providing enhance steering. The anti sway bars currently remain standard.

The softer front shocks are intended to provide slightly more grip to the front end in the hope of providing additional bite that will in turn reduce the strong under steering quality of the Carrera 4.

Initial impressions are that the car's body roll has been reduced , whilst turn in is more positive. When pushed harder, however, under steer is still prevailing, with body roll being slightly beyond comfortable limits (unless a good set of racing seats are installed at which time less time need be spent reinforcing one self against the door etc.). Perhaps thicker anti sway bars will be installed front and rear in the near future- this should minimise body roll without significantly affecting ride comfort in a straight line.

Unfortunately, ride comfort has been somewhat compromised, with tram lining over highway joints becoming more noticeable (this is also a function of the larger 17" rims fitted). The lowered ride height has not proven to be a significant problem (1" lower) with the car clearing most humps and hills.

# Complete 964

## Wheels

### General-

Wheels are always the most obvious way to aesthetically change the look of a car.

Indeed, the original 16" wheels, whilst providing excellent handling and ride, do not necessarily portray an image of aggression usually associated with super cars.

As a result, owners of 964's usually upsize their wheels to either 17" or 18" rims. Note that both diameter rims can fit the 964 with no problems.

Indeed, all one has to be careful of is to ensure offset is correctly achieved with spacers, and clearance made under the wheel arches by rolling the wheel arch lips. Rolling of the lips is easily accomplished by body repair shops, or preferably at a Techart technician with the proper tools (they can roll wheel arches without requiring repainting etc- indeed rolling can be accomplished in a matter of hours for all four arches!).

The best way to purchase rims is from shops experienced in Porsche's as they will be fully aware of the rim and tyre sizes required. As a rule of thumb, the maximum achievable sizes that should work are as follows-

### Carrera 2/4

- front 8.5x17" - 235/45,17 or 8.5x18" - 225/40,18.
- rear 9.5x17" - 275/40,17 or 9.5x18" - 265/35,18.

### Turbo

- front 8.5x18" - 225/40,18.
- rear 10x18" - 265/35,18.

The best brands to look out for (besides factory original examples which are incredibly expensive, and usually manufactured by the same people) is



Author's choice of rim is the 996 17" original Porsche rim.



Another option are the excellent RUF design 17" rims.

Speedline, BBS, RUF, Techart and Fikse.

### The Author's Car-

Rims of choice were the new Porsche 996 17" (rears 9J x 17, 55mm offset and front 7J x 17, 55mm offset)-also seen on the Boxster as a cost option.

The width and offsets exactly match those recommended by Porsche for the Turbo Look 964 models (although the rear rims are slightly wider with a corresponding change in offset to compensate, when compared against the recommended rims for the standard narrow body C2 and C4- 7J x 17, 55mm front which is perfect, and 8J x 17, 52mm rear which is marginally narrower than the 996 rims)

Whilst offset and width of the rear rims is not identical to those recommended by Porsche, the wider rear rims posed absolutely no problem. In fact, the only area to be watched relates to the front inner tyre which can graze against the inside wheel arch at full steering lock (even though the rim size is recommended by Porsche)- a set of 5mm spacers, or a steering stop can easily fix this.

# Complete 964

## Body

### General-

As with any automobile, body modifications are available for the 964 from mild to wild. Whilst some owners would not touch a thing on their car's, others feel the need to customise every aspect of their car.

Various suppliers provide a range of body modifications for the 964, though perhaps the wildest designs have to-date come from Strosek. Strosek has produced a range of body conversions that include the incredible "shark eye" wide body conversion, down to a simple front and rear bumper change. Note that imitation/reproductions of these body kits are also available.

RUF (on their 964 models) were rather conservative by comparison. Perhaps their most notable change was the removal of the rain gutter along either side of the roof line, and the inclusion of a Carrera whale tail to accommodate the intercoolers of their modified vehicles. Less notable changes included a one piece front spoiler.

Techart, likewise provide subtle modifications that include front spoilers, clear indicator lenses, rear RS imitation bumpers and wings.

A note on wide body conversions- if your car is a standard narrow body, modification to wide body will restrict performance given the greater air resistance, additional weight and requirement for significantly larger spacers on the wheel hubs.

### The Author's Car-

Rear bumper was modified to the RS look (original Porsche part utilised). In addition, a Techart front three piece spoiler was utilised as were clear indicator lenses.

All subtle changes that have not affected the car's performance in any way but have modernised the car somewhat.



Author's Techart 3 piece front spoiler (can be colour coded).



Clear indicator lenses add an updated feel to the car.



<b>Engine</b>	with catalytic converter	without catalytic converter
Number of cylinders	6	
Bore	100 mm	
Stroke	76.4mm	
Cubic capacity per 88/76/EWO	3600cm <sup>3</sup>	
Compression ratio	11.3:1	
Engine output per 80/1269/EWG	184kW(250 HP)	
at crankshaft speed	6100 rpm	
Torque per 80/1269/EWO	310 Nm (31.6kpm)	
at crankshaft speed	4800rpm	
Specific output	511 kW/l (69.4 HP/liter)	
Minimum fuel octane requirement	RON 95/MON 85 (only unleaded premium per DIN 51607)	RON 95 / MON 85 (unleaded premium per DIN 51607 or unleaded premium per DIN 51600)
Fuel consumption (liters/100 km)	Carrera 4 Carrera 2	Carrera 4 Carrera 2
at 90 km/h	7.8 7.8	7.8 7.8
at 120km/h	9.1 9.2	9.1 9.2
City cycle	17.6 17.1	17.6 17.1

Engine oil consumption	up to 1.5 liters/1000km	
Maximum engine speed	6700 rpm	
Spark plugs	Bosch FR 5 DTC	
Spark plug gap	0.8 + 0.1 mm	
Battery	12V, 72Ah	
Alternator	1610W/115A, alternating current	
Ignition sequence	1-6-2-4-3-5	
Ignition	electronic, contactless, dual ignition, knock control	
ignition angle control	digital engine electronics	
	2xAV10/9.5 x 776La	
Alternator drive belts	AV 13/12.5 x 1080 La j	
Air conditioner compressor drive belts	intake and exhaust valve: 0.10 mm	
Valve clearance (engine cold)		







## Power Transmission

### Carrera 4



Rear engine, rear-mounted transmission, connected to rigid drive unit between rear-wheel and front-wheel differentials by connector tube. Transaxle. Torsionally elastic drive shaft mounted in transaxle tube between rear and front drives.

Constant torque distribution by planetary gear in rear axle drive:

-  31 % to front wheels
-  69 % to rear wheels.

Longitudinal clutch interlock is controlled on the basis of axle slippage.

The lamellar clutches in the longitudinal and transverse interlocks can be engaged using a full-interlock button, but only at speeds below 30 km/hour

### Carrera 2

Rear-mounted engine and gearbox bolted together to form single drive unit. Drive to rear wheels via dual aniculated shafts.

---

## Transmission

Dry disc clutch

9' Porsche interlocked synchronous transmission

Gear ratios:                      Carrera 4    Carrera 2

1st gear                              3.500:1    3.500:1

2nd gear	2.118:1	2.05 9:1
3rd gear	1.444:1	1.407:1
4th gear	1.086:1	1.086:1
5th gear	0.868:1	0.868:1
Reverse	2.857:1	2.857:1
Final drive ratio:	3.444:1	3.444:1

---

---



## Weights

	Carrera 4	Carrera 2
Empty weight per DIN	1450 kg	1350 kg
Maximum gross weight	1790 kg	1690 kg
Maximum axle load, front*	760 kg	710 kg
Maximum axle load, rear*	1050 kg	1050 kg
Maximum trailer load, unbraked**	500 kg	500 kg
Maximum trailer load, braked**	1200 kg	1200 kg
Maximum towed weight	2990 kg	2890 kg
Maximum supported load	75 kg	75 kg
Maximum roof load***	75 kg	75 kg

\* The maximum gross weight must not be exceeded.

**NOTE:** If additional accessories are installed (air conditioner, etc.), the usable load will be correspondingly less.

\*\* Maximum 16% grade (applies only to original Porsche trailer outfit).

\*\*\* Applies only when original Porsche roof rack frame is used: otherwise roof load is 35 kg.

## Dimensions

(at maximum gross weight)

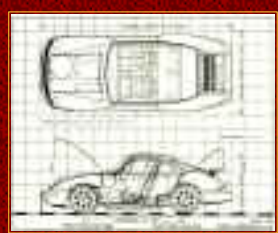

Length	4,250 mm
Width	1,652 mm
Height (empty weight)	1,320 mm
Wheelbase	2,272 mm
Ground clearance*	120 mm
Front track	1,380 mm
Rear track.....8 J x 16 rims	1,374 mm
Rear track.....7 J x 16 rims	1,369 mm
Turning circle	???? mm
Overhang angle front*	?12.0°
Overhand angle rear*	12.0°
* At DIN empty weight	



<b>Tyres, Rims, Wheel Alignment Data</b>	Front	Rear
Summer Tyres	205/55ZR16, 6Jx16 H 2 rims, ro 52.3mm	225/50ZR16,8 Jx16 H 2 rims, ro 52.3mm
Winter Tyres	205/55R 16 88 Q M+S, 6Jx16 H 2 rims, ro 52.3 mm	205/55R16 88 Q M+S or 225/50R16 92 Q M+S,7Jx16 H 2 rims, ro 55 mm or 205/55 R16 88 Q M+S or 225/50R16 92 Q M+S, 8Jx16H 2rims, ro 52.3mm
The load capacity coefficient (e.g. 88) and maximum speed code letter (e.g. 0) are minimum requirements		
Snow Chains	Chains can be mounted only on the rear wheels; maximum speed 50km/h. Use only Porsche-authorized snow chains. Snow chain clearance can be guaranteed only on the following tyre + rim combination: 205/55R16 88 Q M+S on 7Jx16 H P2 rim, ro55mm	
Tyre Pressures (tyres cold)	front 2.5 bars overpressure (36 psi), rear 3.0 bars overpressure (44 psi). These tyre pressures also apply to winter tyres.	
Spare Wheel	165-158 PR 89 P collapsible tyre on 51½ J x 15 rim. Tyre pressure, for use as front or rear wheel	
Camber*	front 0°±10' (max. left-to-right difference 10'); rear -20' ± 10'	
Toe-in*	front +15' ± 5'; rear +10' ± 5' each wheel	
Angle Difference*	at 20° lock: -40' ± 30'	
Caster*	4°10' ± 15' (max. left-to-right difference 15')	
*At DIN empty weight (vehicle unloaded but fuel tank full).		



<b>Capacities</b>	
Engine	<p><b>Total oil capacity</b> ca. 11.5 litres</p> <p><b>Oil change:</b> Requires about 9 litres. Reference indication is the level on the oil dipstick, measured with the engine idling at normal operating temperature.</p>
Transmission and Differential	<p><b>Carrera 4:</b> Front axle: ca. 1.2 litres; Rear axle: ca. 3.8 litres. SAE 75W 90 gear oil, API classification GL5 (or Mil - L 2105 B).</p> <p><b>Carrera 2:</b> SAE 75 W 90 gear oil, API classification GL5 (or Mil - L2105 B).</p>
Fuel Tank	<p>77 litres, including ca. 10 litres reserve.</p> <p><b>Vehicles with catalytic converter:</b> Only unleaded premium per DIN 51607, minimum octane number RON 95 / MON 85</p> <p><b>Vehicles without catalytic converter:</b> Only unleaded premium per DIN 51607 or leaded premium per DIN 51600, minimum octane number RON 95 / MON 85</p>
Brake Fluid Reservoir	<p><b>Carrera 4:</b> ca. 0.75 litres use only brake fluid meeting SAE J 1703, DOT 3 or DOT 4</p> <p><b>Carrera 2:</b> ca. 0.34 litres use only brake fluid meeting SAE J 1703, DOT 3 or DOT 4</p>
Windshield Washer	7.4 litres
Intensive cleaning system	ca. 0.7 litres. Use only Porsche Special Silicon Cleaner.
Power steering	ca. 1.0 litres ATF hydraulic fluid (Dexron)



# Driving Performance\*

	Carrera 4	Carrera 2
Top speed	260km/h	260km/h
Acceleration 0 - 100 km/h	5.7 seconds	5.7 seconds
Standing-start kilometre	25.5 seconds	25.2 seconds

At DIN empty weight and half load. without performance-inhibiting extra equipment (air conditioning, special tyres, etc.)

Full-Power Curve

Acceleration Curve

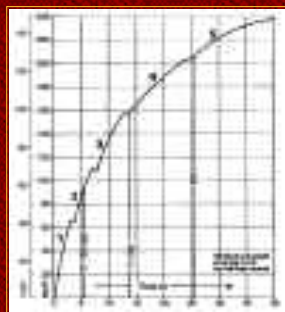
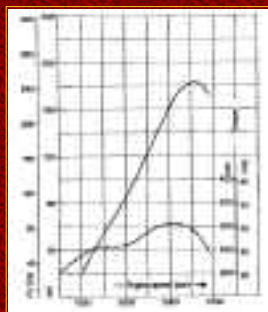

The above reproduced from Porsche's 964 manual.

## C2 vs. C4 - The Performance Story

Top Speed			Acceleration in Gear		
	Carrera 2	Carrera 4		Carrera 2	Carrera 4
Mean	158 mph	156 mph	<b>Fourth Gear</b>	<b>secs</b>	<b>secs</b>
Best	160 mph	159 mph	20-30	5.7	6.3
			30-50	5.4	5.8
<b>Acceleration from Rest</b>			40-60	5.4	5.9
mph	<b>secs</b>	<b>secs</b>	5 0-70	5.5	5.9
			60-80	5.3	5.8
			70-90	5.0	5.7

0-40	3.0	2.9	80-100	5.1	5.6
0-50	4.0	4.0	90-110	5.3	5.9
0-60	5.1	5.2	100-120	6.0	7.0
0-70	6.7	7.0	<b>Fifth Gear</b>		
0-80	8.3	8.8	20-30	8.2	-
0-90	10.2	11.0	30-50	7.5	7.9
0-100	12.7	14.0	40-60	7.3	7.9
0-110	15.3	17.4	5 0-70	7.4	8.2
0-120	18.7	21.3	60-80	7.6	8.4
0-130	23.7	27.5	70-90	8.1	8.8
Standing 1/4 mile	13.6	13.9	80-100	8.1	9.1
Standing km:	24.6	25.5	90-110	7.7	9.2
30-70mph thru gears	4.6	5.1	100-120	8.2	9.9
			110-130	8.2	9.7
			120-140	-	11.7

Carrera 2 vs. Carrera 4 Performance Story reproduced from Autocar and Motor - 6 December 1989. See [History](#) for full story

## Climbing Performance

	Carrera 4	Carrera 2
1st gear	86%	70.7%
2nd gear	41%	46.1%
3rd gear	24%	27.1%
4th gear	15%	17.6%
5th gear	11%	12.2%



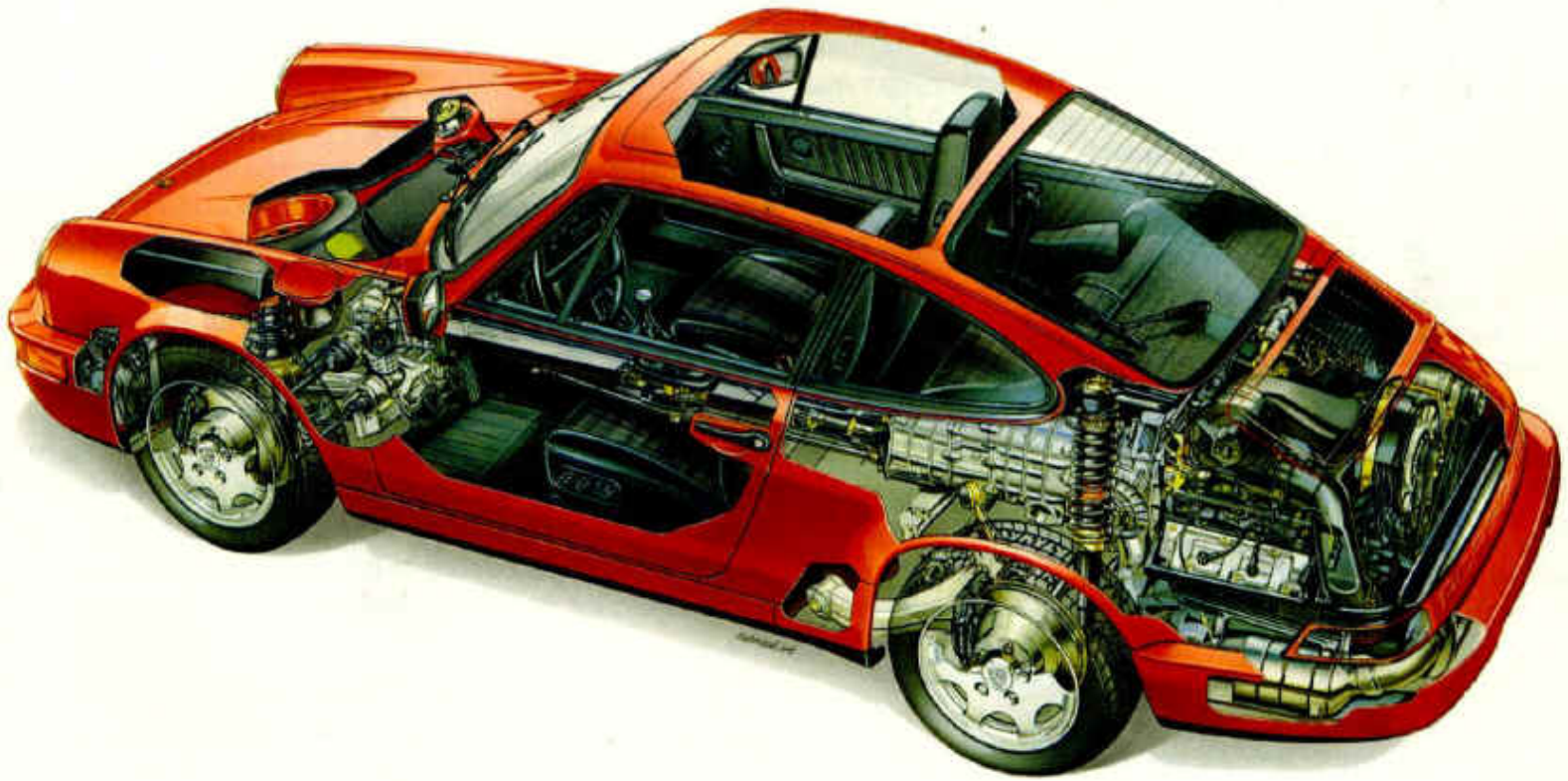

# The Complete History of 911



911s from different years. Can you recognise them?  
(from near to far: 964RS, 911RS 2.7, 911 Club Sport)

## Development



The root of 911 can be traced back to well before the WWII when Ferdinand Porsche created Volkswagen Beetle. However, let us skip such lengthy history and jump to Porsche 356, the predecessor of 911.

356 was the first car carrying the name "Porsche". Based on the Beetle's drive train, further finished with a drag-free body and Porsche's own chassis, it became the most beloved sports car in the 50s accompanied with Jaguar XK120. Despite of frequent updating, its upgradability finally ran out in the 60s because of its

VW origin. As a result, Ferry Porsche started working on the drawing board again to create a new sports car.

*'As early as 1956 we started with the plans for a new model,' recalled Ferry Porsche. 'It was to be a comfortable touring car but, unlike the 356, parts from the large-series cars were not utilised as these were no longer suitable for further development.'*

*'Various models were designed, even some with a notchback with the aim of creating a true four-seater. But finally it remained a sports car in concept, with 2+2 packaging. We didn't want to allow the Porsche shape, which had become world famous in the meantime, to disappear. As a power unit, a 6-cylinder engine was chosen. But then it occurred to me, remembering our motorsport activities, that front engines were not competitive enough on a long term basis, and so we kept to the rear engine.'*

Early project name was "Type 7", it was soon renamed to "901". However, as Peugeot objected to the use of its traditional three figures designation with a zero in the middle, Porsche simply changed the name to 911.

The project was handled by body engineer Erwin Komenda. Ing Hans Tomala was responsible for engine development. Ferry's nephew, Ferdinand Piech (now VW's boss), joined at the final stage as chief of engine development. On the other hand, Ferry Porsche's own son, Butzi (who is a stylist rather than an engineer, now heads Porsche Design), designed the shape which later became one of the most memorable icon in automotive history.



Ferry Porsche (1909-98) -  
The father of 911. He died in  
the same year as his brainchild.



A popular photo - Ferry Porsche  
and 911



Butzi Porsche styled the 911

Ferry himself, although without designing the car by himself, made every important decision, such as the general layout, the use of overhead camshaft and ruling out Komenda's "4-seater" concept. Remember, he was a very good engineer who designed 356, so his decisions were usually correct. Managing the whole project, he certainly deserved to be called "the father of 911".

Of course, there were many problems occurred during the development. However, we skip that and would rather show you the final result, the 911 which was unveiled in the 1963 Frankfurt motor show:

## Technical Highlight of the Original 911 (1963)



### Styling :

911 preserved the general shape of 356, but with slightly better aerodynamics - 0.381 vs 0.40. Butzi Porsche did not created a very handsome shape. However, it was undoubtedly a very unique design that everyone can easily recognise.

**Chassis :**

Chassis structure was conventional steel monocoque (Galvanised steel was not arrived until 1971). Surprisingly, it was 2.4 in narrower than the 356, but the wheelbase and overall length are 5 in and 6 in longer respectively, thus enabled considerably more interior space.

Given the rear-engined layout, weight was inevitably biased towards the rear end - 40 : 60 distribution between front and rear wheels. Porsche claimed this could free up the steering weighting without the use of servo, thus avoided any artificial feeling.

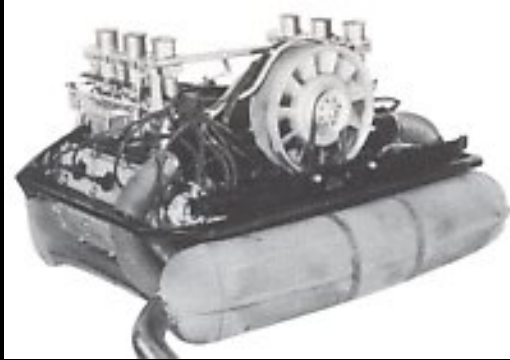
**Engine :**

The flat-six air-cooled engine employed single overhead camshaft per bank instead of pushrod of the 356. Power jumped dramatically to 130 hp from merely 2 litres, still very impressive by nowadays' standard. Note that dry sump lubrication was opted for the benefit of motor racing.

Sufficient space was preserved for future enlargement to 2.7 litres, however, it was eventually sketched to 3.8 litres!

*'Had I known, at that time, that the unit could actually be stretched to 3.3 litres and still be completely reliable, even in racing form, I would almost certainly have decided that it was unnecessarily large and heavy, and would have asked the designers to scale it down', said Ferry Porsche, 'Now I am glad I didn't!'*

**Gearbox :**

Of course was Porsche's patented synchromesh unit, with 5 speed.

**Suspensions :**

Disappointingly, Porsche placed luggage space in prior to suspensions, therefore it adopted space-saving MacPherson struts in the front, with the aid of lower wishbones. In the rear, again the space problem led to the use of semi-trailing arms. However, it was still a big improvement over 356's swinging-axles.

# The Complete History of 911

## Test Report of the Original 911

(by Motor magazine, 1964)

Motor, the leading British car magazine then, performed a very first test on the original 911 in 1964. Instead of reproducing the whole long article, I quote the most important parts in below :

### Overall



The subdued and pleasing noise from the back tells you where the engine is and so does the freedom from wheel spin and the ability to use a lot of the power on corners. But rear-engined handling characteristics have virtually disappeared - there are many front engined cars which are more sensitive to crosswinds and very fast roll-free cornering can be enjoyed with no worries about losing the tail except in special circumstances.

Performance figures show that the 911 is a very much faster car than its production predecessors; a maximum speed of 130mph on 130hp says a lot for the drag coefficient and the acceleration times are astonishing for a 2-litre car weighing over a ton. It really comes into its own on long high speed journeys when the very smooth six cylinder power unit can be kept continuously in its best torque range between 3,000 and 6,000rpm by very free use of the superb, five-speed gearbox - this is no car for top gear drivers. Above all, it has that effortless feeling which suggests that hard driving is what it is designed for and will never wear it out prematurely.....

### Engine



The engine doesn't like pulling hard below 1,500rpm and it only gets into its proper stride between 2,500 and 3,000rpm; after this it runs with complete smoothness and lack of strain to the rev limit of 6,800rpm. During the maximum speed runs the tachometer needle was sitting almost exactly on this limit at 130mph. It isn't a silent power unit -

at low rpm there is a rumbling, rattling noise, which probably comes from the transmission, but once it rises into useful torque range there is nothing but a smooth mechanical whirr and a hard, deep and very subdued exhaust roar which together form just the right accompaniment to fast motoring in a car this purposeful character.....

## Transmission

The synchromesh has that smooth, slicing action which is a Porsche speciality, the ratios are very close together and the gears are almost silent except at low speeds. To be always in the right gear for the present or potential situation demands little physical effort but a certain dedication and forethought which some will enjoy and others disdain.....The clutch operation doesn't quite live up to this standard. It is light but it has a long travel and an 'overcentre' feel.....

## Handling



The 911 is the clearest reputation yet of the theory that rear-engined handling problems are insoluble without reverting to extreme counter measures which themselves have undesirable side effects. The basic oversteering influence of a 40/60 weight distribution is counteracted largely by a very high roll stiffness at the front and a considerable difference between front and rear wheel camber settings.....

In fact, one might almost criticise the handling on the grounds that it is too neutral - the car can be pushed up to its very high cornering speeds without a clear indication to the driver of what will happen when it finally lets go. On dry roads this doesn't matter very much - it is most stable accelerating round a corner, when it maintains a very mild understeer, but the limits are so high that few people will reach them on public roads. On slippery surfaces the German Dunlop SP high speed tyres still grip tenaciously but the back end will break away if you use too much throttle in a low gear, or if you corner too fast on a trailing throttle - a moderate amount of power gives the best results. If you want to drive near the ragged edge you must remain alert because of the usual early warning symptoms of roll, tyre squeal and attitude change are almost absent.....



.....this gives the steering a rather lively feel - camber changes, bumps, ridges, all feed back their messages quite strongly ( but not harshly ) to the driver's hands, particularly when cornering fast.....

# Brakes

An unusual feature of the all-disc braking system is that it uses a duo-servo drum handbrake - the drums are incorporated in the centre portion of the rear discs. This is very powerful....no fade or roughness....they are light to operate and they showed very high stopping power on a dry road.

## Performance Test

All data were recorded by **Motor**

### MAXIMUM SPEED :

5th gear ..... 129.8  
mph  
4th gear ..... 105 mph  
3rd gear ..... 87 mph  
2nd gear ..... 60 mph  
1st gear ..... 37 mph

### ACCELERATION :

0-30 mph ..... 2.8  
sec  
0-40 mph ..... 4.4  
sec  
0-50 mph ..... 6.3  
sec  
0-60 mph ..... 8.3  
sec  
0-100 mph ..... 24.3  
sec

Standard 1/4 mile :  
16.1 sec

### FUEL CONSUMPTION

:  
Touring : 23.2 mpg  
Overall : 19.2 mpg



No headrest yet



Dog seat from beginning

# The Complete History of 911

## Early Handling Problems and Solutions



The rear-bias was always a problem to 911's handling. Any tail-heavy cars have a tendency to oversteer. If such oversteer is not adequately suppressed, lost of control may occur. Although there were some racing car being more tail-heavy and more powerful yet had fabulous handling, say, the 1000 hp 917 Can-Am race car which carried near 70% weight at the rear, the production 911 lacked their racing-spec aerodynamic aid as well as racing tyres - the original 911 rode on 165 tyres with 4.5 in rims only !

To solve the problem, the suspension setup, that is, toe-in, camber, castor etc, should be accurately tuned to optimise the handling ability. However, in production line, such strict tolerances were found to be impossible to be implemented. Therefore the following corrective actions were taken :

1. The earliest makeshift solution was to add weight to the front end. Two 11 kg cast iron weights were added to the bumper of those 911s with unsatisfactory handling found, officially called "bumper reinforcement" because it was nothing to proud of. In fact many drivers of these 911 even didn't know about it !
2. Later, facility was added to adjust the upper location of the MacPherson strut, making it possible to adjust both castor and camber to the very close tolerances. As a result, "bumper reinforcement" was dropped.
3. In 1969, wheelbase was extended by 2.3 inches by moving the rear axle rearward. At nearly the same time, wider tyres were adopted, wheel rims widened to 5.5 in and then 6 in. These changes effectively improved its handling a lot.
4. In the following years, tyres were continuously widened, from 165 of the original car to 205 front and 245 rear of the 993. Turbo 993 even adopted 225 and 285 tyres. (note that rear



tyres were wider than front) Lost of rear end became very difficult as a result.



5. Aerodynamic also improved. In 1972, "Duck tail" rear spoiler was introduced in the 911 RS 2.7. It reduced the rear aerodynamic lift by as much as 75%, thus greatly improved high speed stability. One year later, an even bigger "whale tail" rear spoiler appeared in the RS 3.0, then spreaded to all other production 911s in later years, completely eliminated rear lift.



In its 34 years' history, Porsche progressively reduced the oversteer manner and eventually built mild understeer into the 911. The car became better controlled, easier to drive quickly but some found less fun than the earlier 911s. However, compare with 996, any 911s still had far more oversteer as well as the fun of challenge.

# The Complete History of **911**

## Evolutions - All 911s in 34 years

( All the details are based on European models )

Year	Model	Description
1964	<b>911</b>	 <p>History started here - the original 2-litre car. No one would have estimated its success in the following 34 years. <a href="#">Spec</a> ; <a href="#">Report</a></p>
1965	<b>912</b>	<p>Since 911 was well dearer than the 356, it was no way to replace the latter. As a result, Porsche created a cheaper version named 912 by installing 356's 1600 flat-4 engine. Nevertheless, this car never achieved much sales success.</p>
1967	<b>911 Targa</b>	 <p>Targa is Porsche's word. In our language is "removable hard top". The early Targa had soft rear window instead of the glass one shown in this '68 model.</p>

1967	<b>911 S</b>	<p>Porsche started to differentiate 911 into 3 versions with different character - 911 was the normal version (to be renamed to 911 L later and then 911 E), 911 S was the sport version with 160 hp (due to higher compression ratio and larger valves), alloy wheels and vent. brake discs....</p> <p><a href="#">Spec</a></p>
1968	<b>911 T</b>	<p>....while the 911 T was the cheapest version replacing 912. Engine detuned to 110 hp with cheaper parts used. Of course, like the 912, fewer equipments and 4-speed manual contributed to the keener price.</p>
1970	<b>911 T</b> <b>911 E</b> <b>911 S</b>	 <p>The series of capacity increment started in this year. Bored out to 2.2 litres, power of 911T, 911E and 911S were raised to 125, 155, 180 hp respectively. They became more powerful, flexible as well as quieter. <a href="#">Spec</a></p>
1972	<b>911 T</b> <b>911 E</b> <b>911 S</b>	 <p>To cope with tougher emission regulations at no cost of performance, the engine was enlarged again. Stroked to 2.4 litres raised power slightly to 130, 165, 190 hp respectively. <a href="#">Spec</a></p>
1973	<b>911 Carrera RS 2.7</b>	 <p>RS stands for Renn Sport. Many journalists regard it as the best 911 of all, mainly because of crispest handling. Porsche made this special edition for GT racing, therefore everything was lightweight. 2.7 litres pumped out 210 hp, enabling the 1-ton RS to out-perform many supercars.</p>

Ducktail rear spoiler as well as the name "Carrera" were used for the first time. [Spec](#) ; [More details](#)

1974

**911**  
**911 S**  
**911 Carrera**



The production 911 also got the 2.7 engine. The 911, now replaced 911T as the basic model, boosting 150 hp (re-rated to 165 hp later). Sport version 911S had 175 hp. The Carrera was basically a RS 2.7 but with more effective whaletail spoiler instead of ducktail and without as much weight-saving treatment. However, the biggest external change to these cars was the US-required 5-mph bumpers, which was successfully styled to make them looked more aggressive.

1974

**911 Carrera**  
**RS 3.0**



Again, to homologate Group 3 GT racing, Porsche built 106 units 911 RS 3.0. I believed I saw one of them in HK. It was evolved from the RS 2.7, with the engine bored out to a full 3 litres and capable of 230 hp. Wider rear fenders and whaletail spoiler added exotic appeal. As it was heavier and had larger frontal area than the 2.7 RS, it was actually no quicker. [Spec](#)

When



1975

## 911 Turbo 3.0

(Type 930)

Porsche assigned a new project number, 930, to a new 911, all insiders knew that it must be a revolutionary variant. Yes, it was the first turbocharged 911, one of the pioneers of turbocharging technology. It wasn't the first turbo road car, however, it was the first to succeed without unacceptable turbo lag and fuel consumption. Power and torque increased dramatically to 260 hp and 254 lbft, thus enable remarkable in-gear acceleration as well as top speed. However, thanks to more weight and full equipment, it was actually slower than the Carrera RS in the hands of good drivers. [Spec](#) ; [More details](#)

1975

## 912E

After 6 years of absence, 912 was back with a 2-litre flat-4 pushrod engine came from Volkswagen. Again, it failed to be popular.

1976

## 911 Carrera 3.0



This one replaced the 2.7 litres Carrera. The 2994 c.c. engine was derived from the turbo 3.0, with the greener Bosch K-Jetronic mechanical injection, it output 200 hp or 10 less than the 2.7 unit. However, fuel economy and torque curve were improved. [Spec](#)

1978

## 911 SC

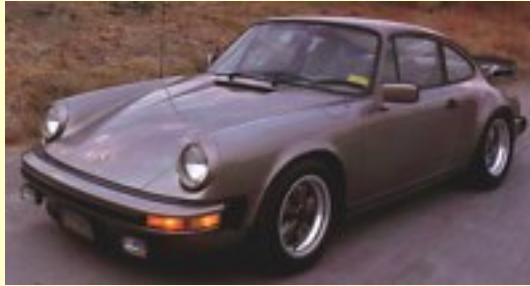

When 928 and 924 had been launched, Porsche's director Dr. Fuhrmann planned to reduce the production scale of 911. As a result, all 911s were replaced by a single model, 911SC, whose 3-litre engine was detuned to 180 hp probably intended to prevent it from having a higher top speed than the 928 (which was supposed to be the successor of 911). Although raised to 188 hp in '80 and 204 hp in '81, it was still relatively unremarkable.

That was the darkest period in 911's 34 years history. Fuhrmann obviously intended to sacrifice 911 to rescue his less-popular, overweight and expensive 928. Luckily, Ferry Porsche was still in favour of his brainchild so that he replaced Fuhrmann with American Peter Schutz. Since then the 911 resumed proper development. [Spec](#)

1978

## 911 Turbo 3.3



(Type 930)



The 3-litre 930 turbo, though fast, did not impress journalists as much as this 3.3 version. With 300 more c.c. and an intercooler, it output a full 300 hp ! Capable to do 0-60 in at most 5.3 sec and top 160 mph. In terms

of acceleration, no rivals could beat it until 1985. No wonder it could be produced until 1990 without any major modifications.

Like the turbo 3.0, no 5-speed gearbox was capable to cope with its massive torque so that 4-speeder was used instead. The fifth ratio eventually came in 1989, thus cut 0-60 to a mere 4.9 sec. [Spec](#) ; [More details](#)

1982	<h2 style="text-align: center;">911 Cabriolet</h2>	<p>Under Schutz's leadership, the first new 911 arrived. It was a cabriolet version of 911SC, also being the first Cabriolet version of 911....</p>
1983	<h2 style="text-align: center;">911 Carrera</h2>	<div style="text-align: center;">  </div> <p>.... however, the real new life started in here - the '83 Carrera was as exciting as the 911SC boring. Although now being the basic 911, Carrera's 231 hp 3.2 engine deserved the "Carrera" name - it could do 0-60 in 5.4 sec and top 150 mph ! Advanced Motronic management system accounted for the higher 10.3:1 compression ratio, hence higher efficiency. <a href="#">Spec</a></p>
1985	<h2 style="text-align: center;">911 Carrera Turbo-Look</h2>	<p>While Dr. Fuhrmann preferred his tailor-made narrow-body 911 turbo, many customers liked this wide-body "turbo-look" Carrera. It did not offer better handling, just added 50 kg extra and more drag. You may call it a "poor" man's 911 Turbo, or a "fool"-man 911 Turbo is also appropriate.</p>
1986	<h2 style="text-align: center;">911 turbo SE</h2> <p style="text-align: center;">(Type 930)</p>	<div style="text-align: center;">  </div> <p>This could be the most beautiful 911 to somebody - incorporated a 935-style "slant nose" with pop-up headlamps. Prepared by Porsche's "Special Requirement Department" for those asked for more power than the regular 911 turbo, the SE had 330 hp, 344 lbft and 170 mph top speed. Bigger turbo boost, larger intercooler and freer exhaust accounted for the power rise, but the deletion of recirculating valve (because no space left) deteriorated turbo lag. Believe or not, it was 80% more expensive than the regular turbo.</p>

1987

## 911 Carrera Club Sport



By deleting equipment, rear seat and sound insulation weighing about 100 kg, Porsche created a faster and crisper Carrera named "Club Sport" or simply CS. Keen drivers liked it very much. Autocar recorded 0-60 in 5.2 sec, a couple of tenth quicker than the regular Carrera. The test car weighed 1182 kg.

1989

## 911 Speedster



Inspired by 356 Speedster, the 911 also got Speedster's treatment - a cut-down windshield and a beautiful hood cover. Based on the 3.2 Carrera body but the "Turbo-Look" body was also available later. Not as water tight as Cabriolet though.

1989

## 911 Carrera 4 (Type 964)



Again, a new project no. indicates this was a great step forward. The 964 Carrera 4 not only improved greatly on aerodynamics (via smooth bumper and auto rear spoiler) and engine flexibility, it also introduced the first ever 4-wheel drive system in 911, which transformed it into an understeerer ! Not everybody liked it though. New 3.6-litre engine output 250 hp with the help of twin sparks per cylinder and high compression ratio, offsetting the dramatic weight increase of 250 kg. [Spec](#) ; [More details](#)





1990

## 911 Carrera 2

(Type 964)

Carrera 2 was the rear-wheel drive version of Carrera 4 with virtually no change in appearance. Without burdening by the 100 kg 4wd system, it became quicker and, more importantly, resumed the oversteer character that many enthusiasts buy 911 for. [Spec](#) ; [More details](#)

1990

## Tiptronic

From 1990, Tiptronic transmission, a Porsche-patented automatic transmission with manual override mode, became available in nearly all 911 versions. Very popular in big cities. [More details](#)

1991

## 911 turbo 3.3

(Type 964)

Turbo was finally applied to the 964 body. Disappointingly, engine was still the 3.3 unit although with larger turbo and intercooler to boost 20 more horsepower from the previous 300 hp. As a result, 0-60 mph was cut down to 4.7 sec. [Spec](#)

1992

## 911 Carrera RS

(Type 964)

Not the best RS. Basically a stripped-out Carrera 2. 50 kg lighter, 40 mm lower ride height, stiffer suspension set up (therefore harsher), brakes came from Turbo. Engine remapped to 260 hp.



1992

## 911 turbo S

(Type 964)

Before the launch of the 3.6-litre turbo, Porsche's racing department created a 3.3 turbo which was even quicker than the 3.6 turbo, that was the 911 turbo S. Through racing treatment (thinner glass, no much equipment, no rear seats, composite door / bonnet / engine lid, stiffer suspensions, lower ride height, extra cooling ducts at rear fenders, hotter cam and breathing, higher boost pressure etc.), it had specifications to amaze: 381 hp, 361 lbft and 1280 kg dry weight, or 190 kg lighter than a standard turbo. According to Paul Frere, it was quite difficult to drive and he preferred the Carrera RS. Only 81 cars were made

to special orders.

1993

## 911 RS 3.8

(Type 964)



Soon after the introduction of the 3.6 litres RS, Porsche decided to fully participate in German, FIA and Le Mans GT

racing series. As a result, an even more racy RS was born. Externally it differed from the 3.6 by wider Turbo-look body shell and biplane adjustable rear spoiler. Aluminium doors reduced kerb weight by 10 kg. The bore was enlarged to 102 mm (remember the original 911 2.0 was 80 mm?) thus displaced 3746 c.c. and pumped out a full 300 hp in road trim. Cylinder wall became so thin that the engine would not be enlarged anymore. Harsh ride not suitable for road use. RSR was the racing version installed with roll cage. A total of 100 RS plus RSR were made by Weissach.

1993

## 911 turbo 3.6

(Type 964)

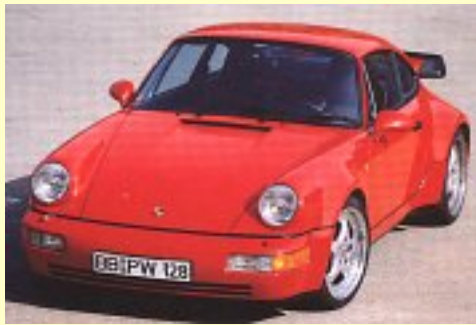

After 14 years of service, the 3.3 turbo engine was finally replaced by a 3.6 unit based on the Carrera 2/4's unit but with conventional single spark. Higher boost pressure and extra

displacement resulted in 360 hp and more important, 383 lbft of torque. Now 0-60 took 4.5 sec. However, it seemed to be merely a stop-gap design without much breakthrough made - for instance, still without electronic boost control. [Spec](#)

1993

## 911 Speedster

(Type 964)



Again, the Speedster came very late. This one based on 964 Carrera 2, which was to be replaced in the same year. Cut-down windscreen, hood cover, no

rear seats ... very familiar, though no Turbo-Look available this time. As the new 993 was far more popular than 964, the Speedster died after less than 1,000 built.

1993

## 911 Carrera 911 Carrera 4

(Type 993)



Project 993 introduced the biggest ever (also final) make-over to the 911 - the most radical was changing the rear suspensions from

semi-trailing arms to multi-link, in addition to wider tracks, improved handling as well as ride a lot. The body received the first major facelift since the first 911, introducing smoother-looking body (if not reflected in drag coefficient), wider wheel arches, raised front bonnet (for more luggage space), reduced slope of windscreen etc., making it look more modern and stylish. Better paint and fit and finish as well. 3.6 engine tuned to 272 hp and 243 lbft by lightweight pistons and con-rods, further up to 285 hp and 251 lbft in 1996 by introduction of Varioram variable intake manifold (first seen in 993 RS 3.8). 6-speed manual instead of 5, Tiptronic also got an extra gear, plus optional Tiptronic S with finger tip control on steering wheel. Carrera 4 used a simplified 4wd system, some regarded it even better to drive (and feel) than the 2wd. 993 was a great success in terms of sales as well as reaction from motor journalists. [Spec](#) ; [More details](#)

1994

## 911 turbo

(Type 993)



No previous turbos followed so close to the development of the Carrera as this one. Twin-turbo gave this 3.6-litre unit 408 hp as well as far lighter turbo lag. Electronic boost control, larger intercooler and 6-speed box also played important roles. With Carrera 4's 4wd system as compulsory, it was nearly as fast as the mighty 959, although it lacked the sharp steering feel as the Carrera. Huge grip and brake. The most accelerative production car then. [Spec](#)

1995

## 911 Carrera RS

(Type 993)



911 RS was always a great driver's car, the last one was with no exception. Still using the 3.8-litre 300 hp 964 RS 3.8 engine but added with Varioram to boost low to mid range torque. The 993 basis provided far better handling. Compare with 993 Carrera, it got 18-in wheels instead of 16-in, front tower bar to stiffen sus geometry, adjustable anti-roll bar, Turbo-size brakes and carried 100 kg less weight (thanks to stripped-out cabin, aluminium bonnet and thinner glass). The most satisfying 911 since the original 911 RS 2.7. Club Sport and RSR versions got usual racing treatment including roll cage, aggressive front spoiler and biplane rear wing. [Spec](#)

1995

## 911 GT2

(Type 993)



As the FIA GT championship was established, Porsche entered a trio to take on different class: 911GT1 (actually a race-developed car with little relationship to 911) targeted at the highest GT1 category, 911GT2 aimed at GT2 class while 911 RSR raced in the lowest category GT3.

911 GT2 was basically a stripped-out (1290 kg) and slightly more powerful (430hp) 911 turbo. The 200 kg weight reduction was achieved by taking away the 4wd system, all equipment and most sound insulation, plus rear seats and used thinner glass. Higher boost led to 22 hp more power. Aggressive front spoiler, biplane rear wing and replaceable wheel arch flares differed it from the regular Turbo. Only 50 road cars were built. [Spec](#)

1996

## 911 Targa

(Type 993)



A 993 Carrera incorporated slidable "glass house" roof developed in conjunction with Mercedes. It added 30 kg but provided open-air fun combined with perfect refinement.

1996

## 911 Carrera 4S

(Type 993)

Turbo-Look version of the 993. Wide body, big wheels and brakes all came from the Turbo, although small movable rear wing remained as the Carrera's.

1997

## 911 Carrera

(Type 996)

Finally, the real 911 retired after 34 years of service. Its successor, 996, was a completely new car linked closely with the Boxster. 996 borrows the great name "911" for marketing advantage.

1998

## 911 Turbo S

(Type 993)



Before the 996 turbo appear in 2000, Porsche relied on the 993 turbo as its performance flagship. However, Porsche also launched an uprated 993 turbo for the US market in 1997, and then an even more powerful European version in Jan 1998, pumping out 424 hp and 450 hp respectively. Further finished with biplane rear wing and 959-like side air intakes. If you cannot distinguish it from other modified 911s, look at the unique yellow brake calipers. This was the fastest REAL 911, also the final version. [Spec](#)

1998

***END***

In April 1998, the last Porsche 911 rolled out from Zuffenhausen factory. Since 1963, a total of 401,232 units were produced, among which 32,335 cars were Turbo, 69,137 were the last generation - 993.



Bye Bye !!

## Specifications of selected models

Model	911 2.0	911 S 2.0	911 E 2.2
Year	1964	1967	1970
Layout	Rear-engined, Rwd.	Rear-engined, Rwd.	Rear-engined, Rwd.
Engine	Flat-6, sohc, 2v/cyl	Flat-6, sohc, 2v/cyl.	Flat-6, sohc, 2v/cyl.
Engine Capacity	1991 c.c.	1991 c.c.	2195 c.c.
bore x stroke	80 x 66 mm	80 x 66 mm	84 x 66 mm
Power	130 hp	160 hp	155 hp
Torque	129 lbft	132 lbft	141 lbft
Gearbox	5M	5M	5M
Top speed	130 mph*	138 mph**	137 mph***
0-60 (0-62.5) mph	8.3 sec*	( 6.8 sec** )	7.6 sec***
0-100 (0-99.5) mph	24.3 sec*	( 17.7 sec** )	N/A
Weight	1040 kg	1050 kg	1020 kg

Model	911 S 2.4	911 Carrera RS 2.7	911 Carrera RS 3.0
Year	1972	1973	1974
Layout	Rear-engined, Rwd.	Rear-engined, Rwd.	Rear-engined, Rwd.
Engine	Flat-6, sohc, 2v/cyl	Flat-6, sohc, 2v/cyl.	Flat-6, sohc, 2v/cyl.
Engine Capacity	2341 c.c.	2687 c.c.	2994 c.c.
Bore x stroke	84 x 70.4 mm	90 x 70.4 mm	95 x 70.4 mm
Power	190 hp	210 hp	210 hp
Torque	159 lbft	188 lbft	203 lbft
Gearbox	5M	5M	5M
Top speed	144 mph*	149 mph*	148 mph*
0-60 (0-62.5) mph	( 6.6 sec* )	5.5 sec*	( 5.5 sec* )
0-100 (0-99.5) mph	( 15.7 sec* )	13.0 sec*	13.7 sec*
Weight	1050 kg	975 kg	1063 kg

Model	911 Carrera 3.0	911 SC	911 Carrera
Year	1976	1978	1983
Layout	Rear-engined, Rwd.	Rear-engined, Rwd.	Rear-engined, Rwd.
Engine	Flat-6, sohc, 2v/cyl, K-Jetronic	Flat-6, sohc, 2v/cyl, K-Jetronic	Flat-6, sohc, 2v/cyl, Motronic
Engine Capacity	2994 c.c.	2994 c.c.	3164 c.c.
Bore x stroke	95 x 70.4 mm	95 x 70.4 mm	95 x 74.4 mm
Power	200 hp	180 hp	231 hp
Torque	188 lbft	195 lbft	210 lbft
Gearbox	5M	5M	5M
Top speed	146 mph**	141 mph*	150 mph*
0-60 (0-62.5) mph	( 6.1 sec** )	6.5 sec*	5.4 sec*
0-100 (0-99.5) mph	( 15.0 sec** )	N/A	( 13.9 sec** )
Weight	1120 kg	1232 kg	1210 kg

Model	911 Turbo 3.0	911 Turbo 3.3	964 Turbo 3.3
Year	1975	1978 / 1983 / 1989	1991

Layout	Rear-engined, Rwd.	Rear-engined, Rwd.	Rear-engined, Rwd.
Engine	Flat-6, sohc, 2v/cyl, turbo, K-Jetronic.	Flat-6, sohc, 2v/cyl, turbo, intercooler, K-Jetronic / KE-Jetronic	Flat-6, sohc, 2v/cyl, turbo, intercooler, KE-Jetronic
Engine Capacity	2994 c.c.	3299 c.c.	3299 c.c.
Bore x stroke	95 x 70.4 mm	97 x 74.4 mm	97 x 74.4 mm
Power	260 hp	300 hp	320 hp
Torque	254 lbft	303 / 318 / 317 lbft	332 lbft
Gearbox	4M	4M / 4M / 5M	5M
Top speed	153 mph*	162** / 162* / 158* mph	167 mph*
0-60 (0-62.5) mph	6.1 sec*	5.3** / 5.1* / 4.9* sec	4.7 sec*
0-100 (0-99.5) mph	N/A	( '89: 12.0 sec*** )	( 11.1 sec# )
Weight	1205 kg	1385 kg	1470 kg

Model	964 Carrera 4	964 Carrera 2	964 Turbo 3.6
Year	1989	1990	1992
Layout	Rear-engined, 4wd.	Rear-engined, Rwd.	Rear-engined, Rwd.
Engine	Flat-6, sohc, 2v/cyl, Motronic, twin-spark, 2-stage resonance intake	Flat-6, sohc, 2v/cyl, Motronic, twin-spark, 2-stage resonance intake	Flat-6, sohc, 2v/cyl, turbo, intercooler, KE-Jetronic
Engine Capacity	3600 c.c.	3600 c.c.	3600 c.c.
Bore x stroke	100 x 76.4 mm	100 x 76.4 mm	100 x 76.4 mm
Power	250 hp	250 hp	360 hp
Torque	228 lbft	228 lbft	383 lbft
Gearbox	5M	5M	5M
Top speed	161 mph**	164 mph**	179 mph**
0-60 (0-62.5) mph	5.2 sec*	5.1 sec*	4.5 sec*
0-100 (0-99.5) mph	( 13.2 sec** )	( 12.9 sec** )	( 9.5 sec** )
Weight	1460 kg	1380 kg	1470 kg



<b>Model</b>	<b>993 Carrera</b>	<b>993 RS</b>
Year	1993 (1995)	1995
Layout	Rear-engined, Rwd.	Rear-engined, Rwd.
Engine	Flat-6, sohc, 2v/cyl, twin-spark, Motronic, 2-stage resonance intake, (Varioram)	Flat-6, sohc, 2v/cyl, twin-spark, Motronic, Varioram
Engine Capacity	3600 c.c.	3746 c.c.
Bore x stroke	100 x 76.4 mm	102 x 76.4 mm
Power	272 hp (285 hp)	300 hp
Torque	243 lbft (251 lbft)	262 lbft
Gearbox	6M	6M
Top speed	166 mph**	172 mph**
0-60 (0-62.5) mph	5.2 sec*	5.0 sec*
0-100 (0-99.5) mph	12.9 sec*	N/A
Weight	1370 kg	1270 kg

<b>Model</b>	<b>993 Turbo</b>	<b>993 GT2</b>	<b>993 Turbo S</b>
Year	1994	1995	1998
Layout	Rear-engined, 4wd.	Rear-engined, Rwd.	Rear-engined, 4wd.
Engine	Flat-6, sohc, 2v/cyl, twin-turbo, intercooler, Motronic.	Flat-6, sohc, 2v/cyl, twin-turbo, intercooler, Motronic.	Flat-6, sohc, 2v/cyl, twin-turbo, intercooler, Motronic.
Engine Capacity	3600 c.c.	3600 c.c.	3600 c.c.
Bore x stroke	100 x 76.4 mm	100 x 76.4 mm	100 x 76.4 mm
Power	408 hp	430 hp	450 hp
Torque	398 lbft	398 lbft	430 lbft
Gearbox	6M	6M	5M
Top speed	181 mph**	184 mph**	est. 186 mph
0-60 (0-62.5) mph	3.7 sec* ( 4.3 sec** )	( 4.0 sec** )	3.9 sec*
0-100 (0-99.5) mph	9.2 sec* ( 9.5 sec** )	( 8.4 sec** )	8.9 sec*
Weight	1507 kg	1290 kg	1456 kg

# 964 Carrera 4 (1989-93)

## *Radical rethinking*



Claimed to be 87% new, believed that or not, the type 964 Carrera 4 was definitely the most radically re-engineered 911 up to then. It had new front and rear suspensions, modern aerodynamics, an advanced electronic 4-wheel drive system and a heavily revised engine. Compare with the previous Carrera 3.2, the 964 seemed like a revolution rather than evolution.

The monocoque chassis was basically unaltered, so was the general body shape that characterised 911 for a quarter of a century. However, the smooth, body-integrated and body-coloured front and rear bumpers indicated the great effort spent to aerodynamics. Instead of the predecessor's 0.42, the 964 achieved a remarkable drag coefficient of 0.32 while generating virtually no lift at high speed. Apart from bumpers, the flat undertrays which sealed front suspension, engine and transmission tunnel also played an important role to reduce drag and lift, so did the automatically raised rear spoiler which replaced a fixed wing. The little spoiler normally acted as ventilation for the engine and recessed smoothly on the engine lid. It raised at above 50 mph and dropped down (for the benefit of engine cooling) at under 6 mph. The movement was quite spectacular to look at.



Rear spoiler rest at low speed ...



... raised at above 50 mph

The flat-six engine received so much modifications that it was given a new name, M64 series. Its major mission was to comply with stricter emission regulations, cope with the considerable weight increase of the 964 without compromising performance. Moreover, it was designed to be a "world engine" - suitable for all markets without any modifications. To achieve 250 hp and 228 lbft output (up from Carrera 3.2's 231 hp and 210 lbft) even in the presence of catalytic converter, it was bored and stroked to 3.6 litres and employed a very high compression ratio of 11.3:1 which was made possible by twin-spark per cylinder and knock sensor. Advancer Motronic program worked in associate with ignition and sequential fuel injection. A 2-stage resonance intake manifold was introduced to improve mid to high speed power.

That enabled the Carrera 4 to sprint to 60 mph in 5.2 sec, slightly quicker than its predecessor. That was very respectable, considering the car weighed an astonishing 250 kg more. It topped 161 mph, which actually matched the contemporary 911 Turbo 3.3, thanks to superior aerodynamics.

For the first time, the 911 received a proper MacPherson strut suspension with concentric coil spring instead of torsion bar. As earlier we have mentioned, the original 911 chose torsion bar in order to give more luggage room at the front. However, as Carrera 4 had the 4WD system already engaged a lot of space, there was no reason to maintain the torsion bar setup. At the rear, a revision of geometry to the semi-trailing arms, plus addition of rubber bushing to pivot joints, enabled a passive rear-wheel steer (inspired by 928's Weissach axle) to counter the oversteering. The new trailing arm was also made in cast aluminium instead of iron.

However, the biggest technology breakthrough must be the intelligent 4-wheel drive, which was simplified from 959. It normally transferred 69% torque to the rear axle, but in case of slide, the electronic control could send more to the wheels which had most traction. Active rear LSD also keep oversteer tightly in check. It was so effective that, accompany with the changes in suspension geometry, many 911 traditionalists criticised it as an understeerer ! In fact, not every motor journalists were convinced that the new-found traction and security of handling justified the lost of involvement. Many regarded it as the most boring 911 after the SC.

The launch of rear-wheel drive version Carrera 2 relieved some pressure from Porsche, but there was still something to be desired. Like the Carrera 4, it rode quite hard and was not all that beautiful. The RS and RS 3.8 were even harsher to live with.



Speedster



RS 3.8

So, what made it one of "the most memorable 911s" ? Radical rethinking. Without a reform like this, the 911 would have never kept alive and popular in its last 10 years, and its successor 993 would have been either unsuccessful or non-existent.

Model	964 Carrera 4	964 Carrera 2
Year	1989	1990
Layout	Rear-engined, 4wd.	Rear-engined, Rwd.
Engine	Flat-6, sohc, 2v/cyl, Motronic, twin-spark, 2-stage resonance intake	Flat-6, sohc, 2v/cyl, Motronic, twin-spark, 2-stage resonance intake
Engine Capacity	3600 c.c.	3600 c.c.
Bore x stroke	100 x 76.4 mm	100 x 76.4 mm

Power	250 hp	250 hp
Torque	228 lbft	228 lbft
Gearbox	5M	5M
Top speed	161 mph**	164 mph**
0-60 (0-62.5) mph	5.2 sec*	5.1 sec*
0-100 (0-99.5) mph	( 13.2 sec** )	( 12.9 sec** )
Weight	1460 kg	1380 kg

\* Tested by Autocar

\*\* Tested by Auto, Motor und Sport

# 993 Carrera (1993-98)

*Almost Perfect !*



No one would have expected the already radical 964 would receive even more radical changes after serving for just 4 years, especially if one used to the rhythm of the car's development. Now, we know Porsche's decision was right - the 993 was not only a refined and modernised sports car, it also delivered a lot more driving fun than its predecessor, bringing the company a revival in sales after the slump in late 80s and early 90s. The mission of 964 was finally fulfilled by the 993.

The success of 993 was partially due to the failure of another car, the still-born 989 sports saloon which was cancelled at the

last stage of development, after 150 million Deutschmarks spent. Without wasting the investment, Porsche transferred the car's advanced multi-link rear suspension to the new 911. That was a double-wishbones-based, 5-link design with aluminium links and mounted on an aluminium subframe which attached to the body via rubber bushings. The result was vast improvement of wheel control, ride comfort and quietness compare with the semi-trailing arm used by all previous 911s. It also enabled passive rear-wheel steering.

The tracks front and rear were widened by 25 and 70 mm respectively, accompanied with quicker steering ratio, ensured a handling to beat the contemporary Ferrari 348 and Honda NSX. In other words, the Carrera became the best handling production sports car.



The most obvious change in exterior was the overall shape - for the first time, 911's ugly "frog's eyes" headlamps were tilted to coincide smoothly with the body, just like the 959. The front bonnet was raised to enlarge luggage space, although that deteriorated aerodynamic drag by one point to 0.33. Both the front and rear fenders were widened to accommodate the increased tracks, but unlike any previous Turbo or Turbo-Look, the fenders integrated smoothly with the body. That said, the body shell was nearly all-new, although the roof rails and roof panel were obviously

unaltered. Chassis strength was increased by 20% without any gain in weight. Overall speaking, the body looked stylish and modern, with high quality painting resulting from the new paint shop and improved fit and finish. The latter must thanks to the introduction of Japanese-style production method by new boss Wendelin Wiedeking.

Least effort was spent to the M64 engine because it was still competitive. Only lighter pistons, lighter con-rods and larger catalyst / silencer were employed to boost an extra 22 hp to 272 hp. Torque were improved from 228 lbft to 243 lbft. On the other hand, magnesium and plastic were extensively used in various parts thus making the engine 6 kg lighter than 964's.

Because the Carrera weighed more or less the same as its predecessor while its frontal area as well as drag coefficient were inferior, it performed just marginally quicker than 964 Carrera 2 (according to Auto, Motor und Sport's measurement). The difference between new and old Carrera 4 was more apparent, thanks to a simpler viscous-coupling 4WD system which weighed half (50 kg instead of 100 kg) and generated less frictional loss.

In 1996, Varioram variable intake system, first seen in the 993 RS of the previous year, was added to all 993 engines. Based on the existing 2-stage resonance intake system, it added a 2-stage long and short manifold system to create a 3-stage device to boost torque across the whole rev range. In addition to larger valves, it output 285 hp and 251 lbft. At mid-range, there was as much as 29 lbft extra torque available.



Therefore, the 993 offered great handling while providing refinement of a modern car. It would have been described as PERFECT, if not facing Ferrari's newer F355. Anyway, it is still certainly the most perfect 911 of all.

The 1995 Carrera RS was even better. Employing a 300 hp 3.8-litre version of M64, with kerb weight reduced to 1270 kg by usual measures, further enhanced with sportier suspensions and brakes etc., it was praised as the best handling 911 after the original RS 2.7.



Rear suspension

# Technical Highlight of 911

## The long-live 901 engine

The Type 901 flat-six engine was as legendary as the car itself. Think about it, although a lot of progress had been made during those years, the basic structure was never altered. For 34 years it remained to be air-cooled and, most important, the basic dimensions (governed by the distance between bore centres) remained unchanged. It sounds rather unbelievable, especially knowing the differences between the earliest and the latest engines - 2 litres versus 3.8 litres; 130 hp versus 450 hp - I can't think of any other engines having so dramatic progress without a complete redesign. Actually, none of the successors of the 901 engine could be called as clean-sheet design. They were all limited by the old-fashion air-cooled and small dimensions.

### Naming

Nevertheless, one thing was changed times to times: the name. From Type 901 (in order to coincide with the car's name, although the latter was eventually changed to 911 under the protest from Peugeot) to Type 911, 930, then renamed to M30 briefly for the turbo, and at last M64. It is generally regarded that the M30 did not worth a new name because it was actually a revised Type 930 Turbo 3.3. In contrast, the M64 had the most changes.

Engine Type	Year	Application
Type 901	1964-70	All 2.0-litre models
Type 911	1970-77	All 2.2, 2.4 and 2.7-litre models, plus RS 3.0
Type 930	1975-89	All 3.0 and 3.3 turbo (excluding 964 turbo 3.3) All 3.0 and 3.2-litre normally aspirated models

M30	1991-92	3.3-litre 964 Turbo and 964 Turbo S
M64	1989-98	All 3.6 and 3.8-litre models

## Advanced design from the beginning

The original engine, Type 901/01 was deemed to be an advanced and highly specified engine for a production car. Its good elements included:



- Aluminium head and crankcase;
- Biral cylinders, i.e., cast iron cylinder liner with aluminium fins casting around;
- Cast aluminium pistons;
- Hollow, sodium-filled exhaust valve for better cooling;
- Forged steel crankshaft;
- 7 main bearings for fully counterweighted crankshaft;
- Hydraulic timing chain for valve gears.

## The trend of evolution

During the 3 and a half decades, the Type 901 engine faced challenges times to times from tightening emission / noise regulations as well as the weight increment. The ask for cleaner emission and more flexibility (thus torque) without any trade-off in performance, cost and reliability guided the development of the engine. Porsche met the demand by increasing engine displacement times to times, plus some other latest development (some were learned from racing program), such as forged pistons, Nikasil treatment, turbocharging, intercooler, electronic fuel injection / ignition, advanced engine management program, variable intake system, twin ignition, low back-pressure exhaust .... the 901 engine and its evolutions met the goals yet achieved considerable improvement in performance.

## Evolutions of normally-aspirated engines

Year	Engine	Application	Litre	HP	Lbft	Major technical update
1964	901/01	911	2.0	130	129	As aforementioned
1967	901/02	911S	2.0	160	132	9.8:1 compression; Forged pistons
1970	911/02	911S	2.2	180	147	Magnesium crankcase
1972	911/53	911S	2.4	190	159	8.5:1 compression for regular fuel; Introduced K-Jetronic for US version

1973	911/63	911 Carrera RS	2.7	210	188	Nikasil treatment for enlarging bore
1974	911/77	911 Carrera RS	3.0	230	203	High strength cast aluminium crankcase
1976	930/02	911 Carrera	3.0	200	188	Standard K-Jetronic
1978	930/03	911 SC	3.0	180	195	Electronic ignition
1980	930/09	911 SC	3.0	188	195	8.6:1 compression
1981	930/10	911 SC	3.0	204	197	9.8:1 compression required 98 RON fuel
1983	930/20	911 Carrera	3.2	231	210	Motronic program; 10.3:1 compression; Freer exhaust
1989	M64/01	964 Carrera 2/4	3.6	250	228	Knock sensor; twin-spark; 11.3:1 compression; resonance intake
1992	M64/03	964 Carrera RS	3.6	260	240	Remaped engine program
1993	M64/04	964 Carrera RS	3.8	300	265	Larger valves; individual throttles; 11.6:1 compression
1993	M64/05	993 Carrera	3.6	272	243	Lightweight piston, con-rod and vavles; freer exhaust
1995	M64/20	993 Carrera RS	3.8	300	262	Varioram
1996	M64/21	993 Carrera	3.6	285	251	Varioram
1997	For reference	996 Carrera	3.4	300	258	All new; water-cooled; dohc 24 valves

## Evolutions of turbocharged engines

Year	Engine	Application	Litre	HP	Lbft	Major technical update
1975	930/50	911 Turbo	3.0	260	254	Recirculation valve for turbo; forged pistons; K-Jetronic; electronic ignition; 6.5:1 compression; 0.8 bar
1978	930/60	911 Turbo	3.3	300	304	Introduced intercooler; 7.0:1 compression
1983	930/66	911 Turbo	3.3	300	318	KE-Jetronic; revised electronic ignition
1991	M30/69	964 Turbo	3.3	320	332	Larger turbo and intercooler; revised ignition; metallic catalyst
1992	M64/50	964 Turbo	3.6	360	383	7.5:1 compression; 0.92 bar
1994	M64/60	993 Turbo	3.6	408	398	Twin-turbo; Motronic with electronic boost control; 8.0:1 compression



# Technical Highlight of **911**

---

## The long-live 901 engine

### From 2.0 to 3.8: the power of Nikasil

It is hard to believe an engine could be enlarged so much without even altering the distance between bore centres. The biggest difficulty faced by engineers was how to squeeze more capacity out of the unchanged dimensions. According to the original calculation - although Porsche had already built in considerable potential for development into the original design - it was expected to be stretched to maximum 2.7 litres only. Anything larger than 2.7 litres required a bore so large that the cylinder wall would have become too thin to be reliable. As the 911 was designed with endurance GT racing very much in mind, and admitted, strong reliability was always one of the core values of Porsche's philosophy, it seemed that the Type 901 engine would have never grown to more than 2.7 litres.



However, a breakthrough was made in the '73 Carrera RS 2.7. It introduced Nikasil technology to get rid of the original Biral cylinder, hence allowing the bore to be grown from the original 2.0-litre unit's 80 mm to as much as 95 mm while still had a sufficiently thick cylinder wall. To understand that, we must have a little bit explanation to the original cylinder design.

Since the first 911, it used so-called "Biral" cylinders, which is basically a cast iron cylinder liner with aluminium air-cooling fins casting around. Why not all-aluminium? because the pistons were also cast aluminium. It is commonly known that the contact between two aluminium surfaces always result in higher friction and wear than the contact between aluminium and iron. Therefore an all-aluminium engine without special treatment is always infeasible. Biral cylinders were employed to solve this problem.

As the Biral cylinder has two layers of different materials made in casting, the cylinder wall is inherently thicker than a pure aluminium cylinder yet doesn't provide superior mechanical strength. Instead of cast iron liner, Nikasil treatment coats a layer of Nickel-silicon carbide, usually by electrolytic deposition, to the inner surface of aluminium cylinders. Since Nikasil layer generates even less friction than cast iron liner, revability and power are both enhanced. Moreover, it is only a few hundreds of a millimetre thick, therefore the bore can be enlarged significantly. Porsche had already tried this technology in the 917 racing car successfully before applying to the 911 RS 2.7.

This was only the beginning. In fact, the Nikasil gave the engine a second phase of life, enabling the bore to be increased to 102 mm (thus displaced 3746 c.c.) eventually. Of course, the stroke was also increased from the 2.7 RS's 70.4 mm to the 3.8 RS's 76.4 mm, thus involving some revisions to crankshaft and con-rods. The magnesium crankcase used since the 2.2-litre had to be changed back to the heavier aluminium one for the advantage of strength.

The production 2.7-litre unit once discarded the Nikasil treatment and in favour of a cheaper arrangement - pure aluminium cylinders matched with iron-coated aluminium pistons, which was just a reversal pair of the original Biral cylinder / aluminium piston. However, as Nikasil had superior power advantage, it was adopted again since the 3-litre engine appeared.

---

# Pioneering Turbocharging



Although turbocharging had been appeared in Chevrolet Corvair and BMW 2002 turbo in the late 60s, Porsche 911 Turbo was unquestionably the first to cure the turbo lag problem and made turbocharging practical for road use.

The advantage of turbocharging is obvious - instead of wasting thermal energy through exhaust, we can make use of such energy to increase engine power. By directing exhaust gas to rotate a turbine, which drives another turbine to pump air into the combustion chambers at a pressure higher than normal atmosphere, a small capacity engine can deliver power comparable with much bigger opponents. As a result, engine size and weight can be much reduced, thus leads to better acceleration, handling and braking, though fuel consumption is not necessarily better.

## Problems

However, no matter the Corvair or the 2002, they failed to make turbocharging practical for road use. The main obstacle was turbo lag. Before low inertia turbine appeared, turbines were very heavy, thus could not start spinning until about 3,500 rpm crank speed. As a result, low-speed output remained weak. Besides, since the contemporary turbocharging required compression ratio to be decreased to about 6.5:1 in order to avoid overheat to cylinder head, the pre-charged output would be even weaker than a normally-aspirated engine of the same capacity !

Turbo lag can cause trouble in daily driving. Before the turbo intervenes, the car performs like an ordinary sedan. Open full throttle and raise the engine speed, suddenly the power surge at 3,500 rpm and the car becomes a wild beast. On wet surfaces or tight bends this might result in wheel spin or even lost of control.

Besides, turbo lag ruins the refinement of a car very much. Floor the throttle cannot result in instant power rise expected by the driver - all reaction will appear several seconds later, no matter acceleration or releasing throttle. You can imagine how difficult to drive fast in city or twisted roads.

## Porsche's Breakthrough

Like BMW, Porsche started developing turbo for the purpose of motor racing. In the early 70s, in order to fight with the 8-litre Chevy in Can-Am, Porsche created the mighty 1000 hp turbocharged, flat-12 engined 917 racer, which soon dominated the whole world. Successful experience led to the application of turbocharging to 911 Carrera RSR Turbo GT racer, which finished 2nd in LeMans. So far, Porsche made turbocharging became the dominating force in GT racing.

Next step was to transform turbocharging for road use. As we have learned, turbo lag was the biggest difficulty preventing turbocharging technology from being practical. To solve this, Porsche's engineers designed a mechanism allowing the turbine to "pre-spin" before boosting. The secret was a recirculating pipe and valve: before the exhaust gas attains enough pressure for driving the turbine, a recirculating path is established between the fresh-air-charging turbine's inlet and outlet, thus the turbine can spin freely without slow down by boost pressure. When the exhaust gas becomes sufficient to turbocharge, a valve will close the recirculating path, then the already-spinning turbine will be able to charge fresh air into the engine quickly. Therefore turbo lag is greatly reduced while power transition becomes smoother.

## Turbo 3.0

This technology was first introduced to the Turbo 3.0 of 1975. The Type 930/50 engine was derived from the RS 3.0, with compression ratio reduced to 6.5:1 rather than 8.5:1, a KKK turbocharger generated boost pressure up to 0.8 bar (governed by a mechanical waste gate). Like the RS, it employed forged pistons, but the fuel supply was changed to cleaner (if less powerful) Bosch K-Jetronic mechanical injection while electronic ignition was first introduced. Power and torque jumped to 260 hp at 5500 rpm and 254 lbft at 4000 rpm respectively, compare with the RS's 230 hp at 6200rpm and 203 lbft at 5000 rpm. The turbo engine was lazier to rev but performed a lot stronger since middle rev, hence providing superior performance in an effortless way.

## Introduction of intercooler

The 3.3-litre version of the turbocharged engine, Type 930/66, superseded the Turbo 3.0 in 1978. It raised output to 300 hp and 303 lbft. The increased power thanks to the use of intercooler between the compressor and the engine, which was located under the rear spoiler. It reduced the air temperature for 50-60°C, thus not only improved the volumetric efficiency (in other words, the intake air became of higher density) but also allowed the compression ratio to be raised to 7.0:1.



In 1983, the 3.3 Turbo was upgraded to Type 930/66, which employed a more sophisticated KE-Jectronic electronic injection and improved ignition. The result was increased torque to 318 lbft although peak power remained unchanged.

The introduction of turbocharger lifted the 911 into the league of supercars. Between 1978 and 85, the 3.3 Turbo was the fastest accelerating production car in the world, beating all expensive opponents from Ferrari and Lamborghini.

---

## The M64 series: pushing to the limit

When the M64/01 engine appeared in the 964 Carrera 4 in 1989, its origin was already 25 years old. The distance between bore centres was never changed, but Porsche managed to increase the bore to 100 mm and the stroke to 76.4 mm (once again employed Nikasil treatment). That resulted in a displacement of exactly 3600 c.c.. Power and torque increased from 231 hp / 210 lbft to 250 hp / 228 lbft, even though now the catalytic converter was standard and emission regulations had been tightened.



Apart from the increase of capacity, most power came from the higher compression ratio, which was 11.3:1 compared with the previous 10.3:1. This was made possible by the introduction of twin-spark per cylinder and knock sensor. The former alone contributed to 10 hp and 3% reduction in consumption, thanks to more efficient burning. The latter was attached to each bank of cylinder and detected the shock wave resulting from knock. From the crankshaft angle, the advanced Motronic engine management system calculated in which cylinder the knock took place, and then retarded ignition in that cylinder. Therefore, the increase of compression was achieved without requiring higher Octane fuel.

The M64/01 engine also introduced a new "resonance" variable intake system which boost mid to high rev efficiency. Each bank of cylinders was fed by a common plenum chambers through separate pipes. The two plenum chambers were interconnected by two pipes of different diameters. One of the pipes can be closed by a valve controlled by engine management system. The firing order was arranged such that the cylinders breathed alternately from each chamber, creating pressure wave between them. If the frequency of pressure wave matched the rev, it could help filling the cylinders, thus improved breathing efficiency. As the frequency depended on the cross-sectional area of the interconnecting pipes, by closing one of them at below 5,400 rpm, the area as well as frequency reduced, thus enhanced mid-rev output. At above 5,500 rpm, the valve opened and increased high-speed efficiency.

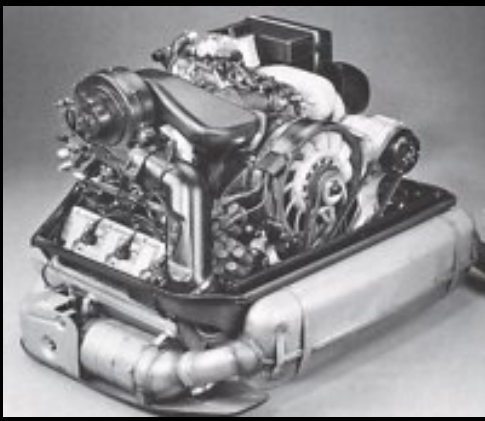

Other changes included:

- 2.2 kg lighter crankshaft;
- Plastic intake manifold;
- increase valve overlapping, higher lift;
- quieter, all-new timing chain tensioners;
- drilled and sodium-filled intake valves, which were lighter and increase rev by 200 rpm;
- ceramic exhaust port liners, which reduce head temperature by 40°C and made sodium-cooled exhaust valves unnecessary.

## M64/05 engine for 993

Modified from the M64/01 engine, with the following changes:

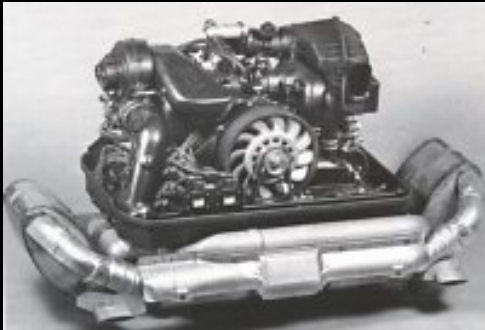

- Lightened con-rods from 632 g to 520 g per piece;
- Lightened pistons from 657 g to 602 g per piece;
- 10 g lighter valves;
- Redesigned cam box;
- Enlarged intake port;
- Freer exhaust system by means of larger silencer and catalyst;
- 98 RON fuel instead of 95 RON;
- Reinforced crankshaft thus made vibration damper unnecessary;

Overall speaking, the engine was 6 kg lighter than the predecessor and rev higher, thus generated more horsepower and torque - 272 hp and 243 lbft.

## M64/21 engine with Varioram

The 993 engine was updated in 1995, mainly with the introduction of Varioram. It was a 3-stage variable intake system based on the existing 2-stage resonance intake. The space-engaging system can be seen easily above the engine (see picture).



The system added six long pipes for low-speed breathing, as longer intake manifolds always lead to lower frequency of air mass thus serve better for low rev cylinder filling. Below 5,000 rpm, only the long intake manifolds were used for breathing, thus resulted in higher torque at such rev. Between 5,000 and 5,800 rpm, the original resonance intake system with short pipes also intervened, but one of the interconnected pipes was closed so to provide better mid-range output. At above 5,800 rpm, both interconnected pipes of the resonance system were opened thus resulted in higher resonance frequency, and of course better filling at such rev.

Besides, the M64/21 engine also employed slightly larger valves. The output was raised to 285 hp and 251 lbft.

**Illustration to Varioram**

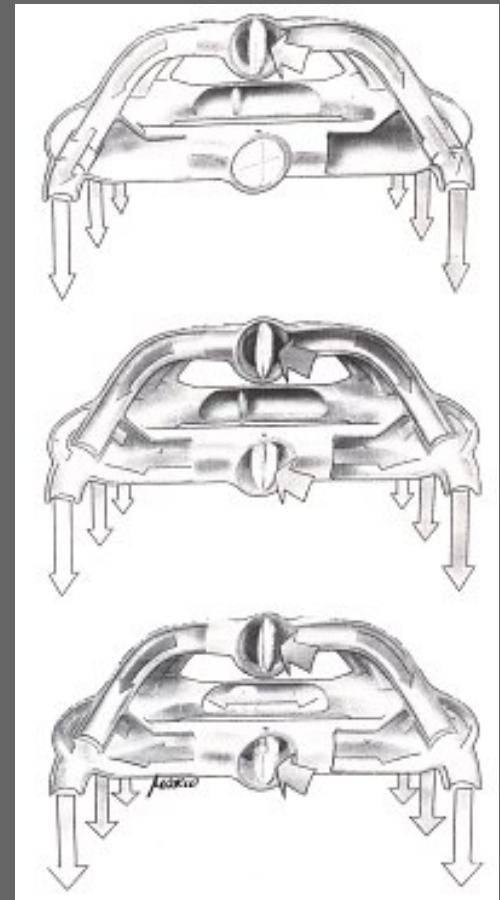
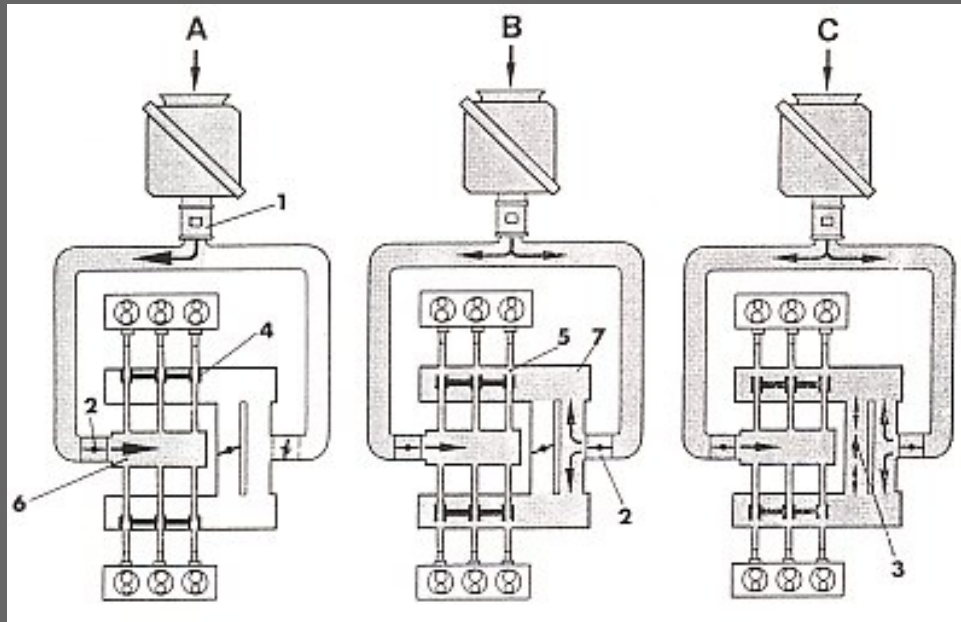

Below 5,000 rpm (left A and top right) : long pipes; resonance intake disabled.

5,000-5,800 rpm (left B and middle right) : long pipes plus short-pipe resonance intake, with one of the interconnected pipes of the resonance intake closed.

Above 5,800 rpm (left C and bottom right): long pipes plus short-pipe resonance intake, with both interconnected pipes of the resonance intake opened.

## M64/60 - welcome twin-turbo

Ignoring minor revisions, the last new engine for the 911 was the M64/60 twin-turbo engine used in the 911 Turbo of 1994. This is not the first turbo based on the 3.6-litre M64 engine - it was the 3.6 single turbo which served the 964 Turbo of 1993. However, unlike its predecessor, it was an advanced design (if not ground-breaking) rather than a stop-gap design, employing a sophisticated engine management system including electronic boost control. In other words, the waste gate was governed by computer, allowing different max. boost pressure for different rev. For instance, a maximum 0.94 bar was available for 3,500 rpm, 0.6 bar for 5,200 rpm and 0.75 bar for 6,500 rpm. This made the engine extremely responsive and linear.

The advanced engine management enabled a rather high 8.0:1 compression ratio to be realised. Unlike Porsche 959, the twin-turbo of the 911 was arranged operated in parallel rather than sequentially. More accurately speaking, each turbocharger was driven by exhaust gas from one bank of cylinders, with individual waste gate. The pressurised fresh air from the two turbines combined together and served all six cylinders. Due to the advanced boost control and 750 c.c. more displacement, the 911 engine actually felt more responsive and linear than the sequential-turbo 959. In torque, the 911 also beat the 7 years older 959: 398 lbft of torque versus 369 lbft, no wonder 4-wheel-drive was compulsory in this Turbo. Ultimate power, however, was less impressive. It was not until the final form, Turbo S, that the 911 can level the 959's 450 hp output.

To cope with the new found output, the twin-turbo got reinforced con-rods and hollow valves cooled by sodium. Like the 3.6 single-turbo, it had single-spark instead of the naturally aspirated engine's twin-spark for simplicity.

# Technical Highlight of 911

---

## Technology Breakthrough

You won't expect too much technical innovation in a rear-engined car. Yes, the 911 was never a good example for advanced technology. However, given the long history we can still find several breakthroughs :

[Turbocharging](#) - introduced in 1975

[4-wheel drive](#) - introduced in 1989

[Tiptronic transmission](#) - introduced in 1990

[Varioram](#) - introduced in 1995

---

## 4-Wheel Drive

The 4WD system used by the 964 Carrera 4 of 1989 was one of the most advanced designs for the time being. It was derived from the 911 Carrera 4x4 racer which won Paris-Dakar rally in 1984, but the experienced learned from the 959 supercar also helped. In fact, Porsche described it as a simplified version of 959's PSK system.

The system employed 3 differentials plus a multi-plate clutch. The epicyclic gear centre differential normally sent 31% to the front axle and 69% to the rear. Although it didn't have 959-style variable torque split, the torque split is not fixed either. A multi-plate clutch incorporated with the centre differential would intervene whenever ABS sensors detected wheelspin at the rear wheels, hence sending more torque to the front wheels. This made the Carrera 4 more sophisticated than the contemporary pure-mechanical Audi quattro system.

The rear differential also incorporated a similar clutch acting as a limited slip differential. Again, the clutch is controlled by computer which got information from ABS sensors in individual wheels. Therefore the rear end of the Carrera 4 could hardly lose grip.

However, the Carrera 4 was far from popular. It was generally criticised as "over-corrected" the flaws of

the tail-happy 911, transforming the car into an understeerer. The understeer was particularly severe when pushing the car to the limit, thanks to the large amount of torque sending to the front axle. Therefore Porsche designed a completely different system in the 993 Carrera 4.

## 993's system

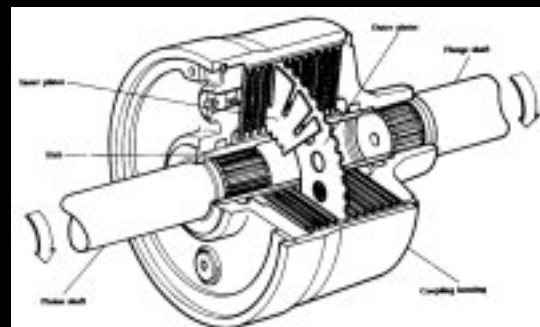

Left: 993's 4-wheel drive system; Right: a typical viscous-coupling differential

In contrast to the 964, the 993's 4-wheel drive system was rather conventional and simple, but it actually performed far superior in real world. Instead of epicyclic differential and multi-plate clutch, it used a simple viscous-coupling LSD as centre differential. To most FF car, viscous-coupling means understeer, but for the rear-wheel-drive-based 911, it means very much loyal to the Carrera 2's character yet provided superior grip when needed.

To make the viscous-coupling always engaged the front wheels, the rear tyres were made marginally smaller in diameter, enhance established a small speed difference between the drive shafts to front and rear. With the speed difference, the viscous liquid normally transferred 5-15% torque to the front axle, which was much less than the 964's system. In abnormal conditions, that is, whenever one axle lost grip, the viscous-coupling LSD may send up to almost 100% torque to the other axle.

Both the center LSD and rear LSD were now pure mechanical, but clever electronics was used in the newly-added ABD (Automatic Brake Differential). Again, ABD was simple yet effective. It was just a program, sharing all the hardware with ABS. Whenever rear wheels spin, it braked the spinning wheel thus the rear differential would send more torque to the other wheel. It was particularly useful for extreme conditions such as on snow, while LSD covered most normal conditions.

The 993's system weighed only 50 kg, that's just half of its predecessor. Energy loss was also halved. It made the 993 Carrera 4 nearly as quick as the RWD version. Production cost was reduced as well.

---

# Tiptronic

Porsche's Tiptronic was the earliest semi-automatic transmission offered by a major car maker. First appeared in 1990 in the 911 as an option, it became available in 968, Boxster and was licensed to Audi and Mitsubishi for production.

Based on an automatic transmission with torque converter, besides conventional auto mode it offers a manual override allowing the driver to shift by pushing the gear lever forward and backward. Faster reaction it may not had, but more fun to the driver was assured.

The auto mode had 5 different programs to suit different driving style, something like the "Sport", "Economy" and "Winter" mode in traditional autoboxes. The computer determined shifting according to driving style. For instance, frequent full-throttle operation and brisk release of throttle indicated a sporting driving mode, thus "fast" program would be selected.

Even in manual mode, the computer might intervene under harmful conditions, e.g. it would shift up without the driver's command if the engine speed had reached the upper limit.

Tiptronic was developed in conjunction by Porsche, ZF and Bosch. Porsche originated the idea, ZF made the gearbox and Bosch was responsible for the electronic control. Little had changed since its introduction :

- 1995 : Tiptronic S introduced steering-wheel mounted fingertip control.
- 1996 : 5-speed Tiptronic appeared in Boxster, instead of the original 4 speed version.



# The 964



Speedster and Carrera 4 received a new face ....



# 964 Valve Adjustment

---

Doing a valve adjustment on a 964 is an easy, straightforward task - but time consuming. If you want to save a few bucks on your annual maintenance costs and get to know your car better, you should definitely start here. First, the question of "how often?" Some people say every 15,000 miles, some say 30,000. Some people say twice a year, some once a year, some say every oil change. Follow your owners manual for the Porsche recommended service interval - but I try to do mine twice a year. One way you can tell when you need an adjustment is by listening. You might hear a slight ticking noise coming from the valve train. This is when valves are too loose. This isn't "dangerous" but just one indicator. Actually, tight valves are dangerous because they increase your engine temperatures and can cause serious damage - but tight valves are silent. Thus, follow your owner's manual or trusted mechanic for interval advice.

## Tools

You need a good set of tools before you begin. In particular, a solid set of metric sockets and wrenches and screwdrivers are a must - preferably, sockets that are of the 6-point variety, rather than the 11-point. This ensures that your socket has a tighter grip on the nut and is less likely to strip out parts.

Make sure you have *good* jack stands and a good jack. Don't skimp here, you'll be spending a lot of time under the heavy end of your car which will be quite a ways up in the air. If you are at all questionable in the stability of your car once in the air, put one or two of your tires laying down under the car just in case of a fall. It's better to destroy a wheel or two than your head.

Valve adjustment tool. I use a standard feeler gauge, but I plan on getting a dial gauge for next time. The feeler gauge works ok - it is just a little more time consuming getting the blade under the foot where you do the measurement. I'll cover the adjustment with the feeler gauge until I do an adjustment with the dial.

## Parts

The parts you need before starting a valve adjustment are relatively simple. But, while you're there, this is a prime time to do all of your major service items. This isn't mandatory - but at least plan on changing the spark plugs, oil and oil filter. You have to remove the same amount of "stuff" to get to the plugs and you drain the oil anyway. So here is your parts list:

<b>Part and Quantity</b>	<b>Est. Price</b>
1 Case of Oil (You'll use 8-10)	~ \$60.00 (Mobil 1)
Oil Filter	~ \$5.95
Air Filter	~ \$12.00
Fuel Filter	~ \$15.00
12 Spark Plugs	~ \$4.50 * 12 = \$54.00
Valve Cover Gasket Kit	~ \$39.00
2 Distributor Caps	~ \$49.00 * 2 = \$98.00
2 Distributor Rotors	~ \$19.00 * 2 = \$38.00
<b>Total</b>	<b>~ \$321.95</b>

---

# 964 Valve Adjustment

---

## Adjusting

---

### 1. Rotate engine to TDC #1.

Before you can adjust anything, you've got to be at TDC (top dead center) for the #1 cylinder. Using a large socket - turn the fan belt pulley to turn the engine *clockwise*. It will be hard to turn with the spark plugs in the car. Some people say that you shouldn't remove the plugs until after the adjustment as small deposits could end up in the valves - throwing off your measurements. You might have to put some pressure to manually tighten the belt down to make it turn the lower crankcase pulley. As you turn the crankcase, watch the lower pulley. There are three notches in the pulley at 120, 240, and 360 degrees. These are the marks for TDC of each cylinder. One of the marks has a **Z1** next to it - which corresponds to TDC #1 - or TDC #4. (Two full turns of the crank are required to fire all six cylinders.) Rotate the engine by the wrench on the pulley nut until the notch with Z1 is lined up exactly with the notch on the fan shroud casing. So you need to be sure you are on #1 instead of #4. There are a couple ways to do this. First, if you have removed the distributor caps, you'll see that the rotor is pointing to either #1 or #4. This is obviously the easiest way to be certain, but I don't like leaving the mess of spark plug wires all over to lose track of while in the adjustment process. The second way is to feel the rockers. When #1 is at TDC, both the intake and exhaust valves will have a slack feel to them because the rocker arm is not being compressed by the cam lobe. try to manually rock the #1 rocker arm back and forth to feel for play. (#1 is on the left - driver's side - all the way to the rear of the engine. (See **Figure 1** below.)

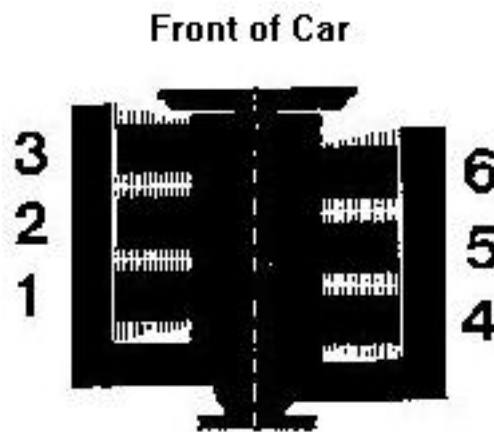

**Figure 1**

Also, feel the #4 rocker arms. Both on one cylinder should be tight while both on the other should be loose. If #1 is tight and #4 loose, you need to rotate the engine by the pulley 360

degrees until Z1 comes back into alignment again. If #1 is loose and #4 is tight, you are set to go.

## 2. Measure gap.

Now that you are certain you are on TDC #1. You need to measure the clearance for the valve stem. Insert the feeler gauge blade between the valve stem and the valve adjusting screw cap. (See the **Figure 2** below.)



**Figure 2**

Getting the gauge in there is *not* easy. The tighter the valve is, the harder this also gets. Because of the room constraints you have on the upper valves, you might want to start under the engine until you get the hang of it. Once you get the feeler gauge in the gap, slide it around and you should feel a "slight drag" on the gauge blade. It shouldn't float free and it shouldn't grab - it should just drag a little bit. You also shouldn't feel any more slack in the rocker arm with the gauge inserted.

If you need to adjust one way or the other, loosen the 13mm retaining nut to free the adjusting screw. This should only take a slight turn on the retaining nut to free the screw. Now tighten or loosen the screw until you achieve that perfect "drag" on the feeler gauge. This screw is pretty sensitive on the adjustment so move slowly. (See **Figure 3** below.)

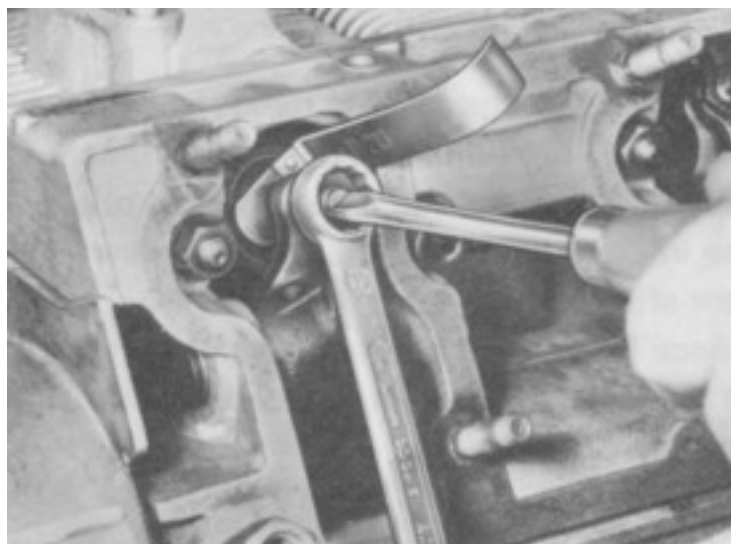

**Figure 3**

Another note here: If you twist the feeler gauge in the gap, it alters the angle it rests on the screw foot. Make sure you wiggle the gauge around lightly until you feel that you are not binding on anything. That binding can also throw off your measurements. This is harder to determine on some of the more difficult valves on top but easier on the bottom valves. Once you have the perfect feel, you need to retighten the retaining nut. Be careful here as many times, the nut will actually turn the screw as well. You need to re-check the clearance after the nut is tightened. When you re-check, always pull the gauge out and start over. Be a perfectionist during the adjustment. You've come this far - don't waste the trip by having misadjusted valves later.

Once you've tightened, rechecked, and are happy with the valve adjustment on that valve, do the other valve on that cylinder.

### **3. Rotate the engine to the next cylinder.**

Now that #1 is adjusted, move to the next cylinder. Rotate the engine clockwise until the very next notch comes into alignment. There is no Z1 on this one, so just make sure you rotate 120 degrees to the next notch.

When you are lined up with the next notch, adjust the next cylinder according to the firing order. The firing order is:

**1 - 6 - 2 - 4 - 3 - 5**

This order is also stamped on a sticker in your engine compartment. So if you've just done #1, adjust #6. Cylinder #6 is all the way towards the front of the car on the passenger side. Incidentally, #6 is about the hardest cylinder to get to as you have the power steering pump over top of the upper valve. Just be patient and take a break every couple minutes to save your back.

After #6 is adjusted, keep going, rotating the engine 120 degrees to cylinder #2, 120 degrees to cylinder #4, - which should have another Z1 marking - 120 degrees to cylinder #3, and finally 120 degrees to cylinder #5.

Once all 6 cylinders have been adjusted, go back through the whole firing order again. After you do an adjustment and rotate the engine over, the cams will open and close each valve, compressing and decompressing each rocker spring. This re-measure will just make sure that none of the clearances drifted - and that you didn't error anywhere.

---

# 964 Valve Adjustment

---

## Prep Work

---

Before you begin - your car has to be **cold**. It is best to park and let your car sit overnight. Don't start the car at all the day you begin or your valves will expand with the heat and your measurements will be off.

### 1. Jack the car.

You've got to get your car up so that both rear wheels can come off. I jack the car from the ridge at the bottom of the crankcase. Just make sure your jack isn't on or near any of the connecting bolts or drain plug and lift slowly until both wheels are up. This will require a good amount of lift, so a small jack won't get the job done - and your factory jack that comes in the car is definitely not a good idea.

Once the back end is up, lower the car onto jack stands and get rid of the jack. Never use just the jack for extended support.

### 2. Remove the rear wheels.

### 3. Remove the engine under tray.

Here is another semi-controversial topic: the tray under the engine. Porsche put it there for aerodynamics, sound reduction, and probably some other reasons. Many sources say it traps too much heat to be entirely good for the extended life of the engine. I - along with many others - have removed mine permanently. Whatever you decide for the long run, this has to go for now. It is held on by a series of bolts across the bottom of the engine.

### 4. Drain the oil.

From the drain plug at the bottom of the engine crankcase and the plug right in front of the passenger side, rear wheel, drain all of the oil from the car.

### 5. Remove oil filter.

You want to start up top getting everything out of the way to get to the valve covers. You might as well remove the oil filter first to help the draining of oil.

### 6. Remove air box cover and filter.

### 7. Remove heater blower motor.

On the left hand side of the engine compartment is the blower motor. From the blower

motor headed down into the engine tray towards the underside of the engine is a tube. Loosen the clamps holding that tube in place and remove the tube and all electrical and air hose connections.

On the left side of the blower motor will be two 10mm bolts holding the blower in place. Remove those two bolts and the blower motor - along with the upper air tube from the distributor/alternator fan shroud - should come right out. Notice the peg in the back of the blower motor that is resting in the rubber grommet behind the motor on the bracket in the back of the engine. You'll need to remember that as the first anchor point on re-installation.

## **8. Remove electrical connections.**

Take the source lead off of the distributor caps - note which wire goes to which cap - and tuck out of the way. Also open the relay/fuse box cover and disconnect the two plugs from the wire running into it from the right. Tuck this out of the way also. The idea here is to have yourself a clear shot to the valve covers below.

## **9. Disconnect Oxygen Sensor lead.**

All the way in the back of the engine compartment - towards the front of the car - you'll see a wire going through a grommet to the bottom side of the engine and to the catalytic converter. Disconnect this wire and push the grommet and wire through to the bottom. This is much easier than trying to remove the O2 sensor - and safer for the sensor.

## **10. Disconnect upper spark plug wires.**

Make sure again that you note which wire goes to which plug. You absolutely do NOT want to get these mixed up later. To make things easier, each wire is different in length and only have one logical way back in, but just make sure you take note of that before you unplug them. For the rest of this procedure - always keep the wire locations and order in mind before disconnecting anything. When in doubt, wrap the ends with masking tape and label them. Once disconnected, tuck them out of the way also.

At this point, you should have complete access to the upper valve covers. Move on to the bottom.

## **11. Remove secondary muffler.**

The muffler behind the passenger side rear wheel is held up by two bolts on one end and one round clamp at the other end. Remove the round clamp and two bolts and it should be free. Be ready to support this as it is fairly heavy.

## **12. Remove catalytic converter.**

The catalytic converter is held up by another round clamp on one end and four bolts on the other end. Your wire for the O2 sensor should already be free from above. When removing the catalytic converter, you should notice that you have new bolts and a new metal gasket in your valve cover gasket kit.



### **13. Remove remaining heat shields.**

On both sides of the engine are extra heat shields to protect the engine from the muffler heat.

### **14. Remove valve covers.**

You should have all four valve covers exposed and readily accessible now. Each valve cover is held in by a series of 10mm nuts. Try to keep the torque of the nuts even across the valve cover in both removing and reinstalling just to make sure you don't crack or stress anything. When you remove the covers you will have direct exposure to the rockers and valve adjustment screws. Be careful not to get dirt or drop anything around here. Extra parts don't go well in there so you might want to consider vacuuming or wiping down the area prior to removing the covers. Take all four covers off.

# 964 Valve Adjustment

---

## Closing

---

You are in alignment - it's time to close things up.

### 1. Re-install valve covers.

Clean the valve covers and all mating surfaces to ensure that no grit or dirt will affect the seal. Place your new valve cover gaskets into the valve cover and carefully place the valve cover back in its position. Install your washers and nuts and evenly tighten. By evenly tightening - gradually work around the valve cover studs, tightening each screw a small amount until each nut is tight. *The nuts do not need torqued heavily!* In fact, the workshop manuals recommend a torque of 9.7 Nm or 7 ft lbs of tightening torque. Over tightening can easily strip the studs or even crack the cover.

Again note that each valve cover is specific to its original position and can not be swapped. The spark plug locations are reversed left to right.

### 2. Change spark plugs.

Now is a good time to change the spark plugs. It is recommended to use the factory toolkit provided spark plug wrench. Just be careful not to cross thread the spark plugs back into the cylinder head.

### 3. Plug in spark plug wires.

Noting their original placement, plug in each spark plug wire until they fully snap into place.

### 4. Re-install lower heat shields.

### 5. Re-install exhaust system.

Using the new gaskets and bolts, re-install the catalytic converter and secondary muffler. Make sure you push the O2 sensor wire back through to the upper engine compartment and re-seat the rubber grommet in place. Later - after you have run the engine for a while - you might want to re-tighten the exhaust studs to prevent leaking after the expand and contract from the heat cycle.

### 6. Close oil drain plugs.

### 7. Change air, oil and fuel filter.

While you still have easy access to everything, it is a good time to do your regular maintenance items. Don't forget the fuel filter. It is just as important as the air and oil filters to keep clean.

## **8. Replace distributor caps and rotors.**

Do this step one wire at a time. The caps and rotors can only go on one way and the firing order is marked on the caps, but hold the new one next to the old to make sure you move wires in the right order.

## **9. Re-install air box.**

## **10. Connect O2 sensor wire.**

## **11. Connect electrical connection to relay/fuse box.**

## **12. Connect main power leads to distributors.**

## **13. Re-install heater blower motor.**

Place the heater blower peg into its grommet towards the back of the engine compartment and insert upper air tube into alternator/fan shroud. Bolt in the two retaining bolts to secure the motor. Connect the lower air tube, all electrical connections, air connections, and tighten all clamps.

## **14. Double check all connections, fitting and bolts.**

This is the time to sanity check all of your work. Make sure you didn't forget to connect or tighten anything. Make sure my directions didn't leave anything out. At this point your car should be entirely back together.

## **15. Fill with motor oil.**

After you've spent so much time working on the car, and so much effort concentrating on the "more important" details, it is surprisingly easy to forget that your engine is still bone dry. It should take about 7-9 quarts of oil for starters.

## **16. Start the car.**

If this is your first adjustment - this is an anxious moment. Just remember that your fuel line is dry from changing the filter so it will have to crank a few extra times and might even sputter out on the first start. Fire it up and let it idle. Obviously, you never want to immediately start revving *any* car when starting cold, but let it idle for a while. Follow your normal procedures for checking and topping off the oil.

Check under the car for leaks and examine around the valve cover seals. Check the exhaust system for leaks.

# Dual Distributor Belt Replacement

Sadly, our 3.6 engines with their dual spark plug set-up suffer a relatively common problem. That little belt that keeps both distributor rotors in synch with each other tends to fail, causing the secondary distributor to stop turning. This can cause anything from minor performance problems to severe engine damage depending on where the second distributor stops and probably a host of other factors. Regardless of how serious some say it is – or how minor it could be – it is a problem that must be corrected without delay.

## Symptoms

I have had two distributor belts fail. One when I first got my 91 C2, the other when I first got my 95 C2. In both instances, the engine ran ok, but suffered from moderate to heavy pinging under load – especially at higher rpm's. Symptoms could vary widely, but any sort of underperforming engine or pinging/knocking noises could be attributed to a potential failed distributor belt.

## Diagnosis

There are a couple ways to verify operation of the belt. First, remove the secondary distributor cap and see if the rotor spins freely. If it spins – at all – the belt doesn't have a hold of it. The other way is to remove the input plug from the top of the primary distributor cap, forcing the car to run on only the secondary distributor. If it starts and runs – no problem. No start, no belt.

## Prerequisites

This job is technically straightforward, but introduces a lot of possibilities for you to hit "snags." For this reason, you will need a solid compliment in the tool department. These will include:

- Full metric socket set with ratchet extensions.
- Screwdrivers.
- Patience.
- Drill with various small metal cutting drill bits.
- An extra pair of hands.
- A good jack. (Not your little factory jack.)
- More patience.
- Good jack stands.
- Vice grips - possibly.

- Possibly a steel shaft and hammer to "coax" the distributor out.
- A clamp to span the length of the main distributor shaft.
- Allen wrenches.
- A refill of patience.
- Needle nose pliers.
- Dremmel tool with cutting/filing bit.
- Steel wool.
- Sandpaper.
- Bearing grease.

Of course, the parts you need are the new distributor belt and a new, 5/32" compression retaining pin.

## Step 1 – Preparation

Before you remove anything, you will want to get your engine ready to have the distributor yanked out. You need things prepped first so that you can reinsert the distributor later at the same place in the firing rotation as when you pulled it.

- Remove the heater blower motor and related ductwork to give yourself some room.
- Remove the distributor caps. Leave the rotors in for now and do not take the spark plug wires off of the caps. Also, be extremely careful when removing the screws holding the caps on. The lock washers on the caps are extremely good at their job. Do not strip the heads off or you'll have to drill the screw heads off.
- Rotate the engine clockwise by the fan pulley bolt until the Z1 indicator mark lines up with the mark on the fan housing indicating that the engine is on TDC#1. Be careful though, Z1 comes by for TDC#1 and TDC#4. Remember that whole two-stroke engine thing – the crank rotates twice for each combustion cycle, but the distributor only rotates once per cycle. Confirm that you are on #1 by the position of the primary distributor rotor. It should be pointing towards the notch on the outer rim of the distributor housing. If the distributor is pointing at #4, just rotate the engine one more turn. Once you are confident that you are at #1 and the rotors confirm this, go ahead and pull the rotor caps and dust shields off the distributors.

## Step 2 – Removal

- Remove the 13mm bolt holding the base of the distributor down.
- Pull the distributor straight out.

***Note:** Removing the distributor can be quite difficult, or it could slide right out. In my case, the shaft did not want to come out to save its life. The explanation was that a vacuum builds behind the shaft. Hopefully, the shaft will come out with some degree of force – pulling with your hands. In my case, I ended up drilling a hole directly beneath the distributor housing and using a steel rod to punch out the distributor from below. Just be careful and use sound and safe judgment so as not to damage the distributor or anything else.*

## Step 3 – Disassembly

This is decision time. Crack it open or ship it off to be rebuilt? As of now, you can get a pro to rebuild your distributor for around \$170 plus shipping. Calculate your own downtime for shipping and repair. Unless you just really want to tackle this on your own, this might be one of those jobs that is worth having someone else do for you.

**!** ***Additional Disclaimer:** I would strongly advise that unless you are quite experienced in mechanical work, you do NOT attempt this DIY. You can run into snags during this process, worn parts, and severe difficulties getting things lined up properly for reassembly that can cause damage to your engine if not done correctly. Also, you can easily expect this job to take anywhere from 4 to 12 hours depending on where and how bad you get stuck. For a lot of people, this just isn't worth the price - judge for yourself.*

Still here, ok then. Get a tall glass of ice water – no beer, you need all the help you can get.

1. Drive Gear removal: At the base of the primary distributor shaft is the drive gear, which is secured in place by a steel retaining pin. This pin is a very soft steel that crushes and mushrooms out at the ends to prevent it from sliding out. Just drill this pin out completely and don't mess with trying to punch it out – it just mushrooms more on impact. Once the pin is out, some pressure will release that causes the gear to slide out some. You will need to continue to pull the gear off of the shaft. Note all washers that are on the base of the shaft for future reference during installation.

2. Connector plug removal: Pull the retaining clip off of the electrical connector plug on the inside of the distributor body. Pull the plug out and using needle nose pliers, remove the connector from the black plastic housing. Push the connector and wires back into the body of the distributor.
3. Primary shaft removal: Remove the 3 phillips screws from the primary distributor body. Once removed, the distributor shaft should pull straight out the top. Again, make a special note of the washers, locations, and positions so you can put them back in the same order.
4. Remove Secondary Shaft Cap: Using a Dremmel tool or similar, file down the 3 places on the bottom of the secondary distributor housing that secure the brass plate in place. Gently pry the cap off. Be very careful not to destroy this cap.
5. Remove Secondary Shaft: Remove the retaining washer from the bottom of the secondary shaft and slide the shaft out. Finally, check those washer positions again.
6. Distributor Housing Separation: Remove the 5 allen head screws holding the halves of the distributor body together. Be very precise in removing these as they could very easily be seized and tend to strip. Get the allen key well inserted into the sockets and turn very carefully. I popped all 5 free first before removing any – just to be sure. There will be two pins that provide some tension and align the halves together so you might need to use a screwdriver blade to gently pry apart the two halves.

You should now have your distributor fully disassembled. At any point in this process, your old belt would have fallen out. Hard to believe that one little belt was given such a critical job.

## Step 4 – Cleaning

- Check for any rust or pitting along any of the shafts or anywhere on the distributor. I used some steel wool to lightly buff any imperfect surfaces.
- Check for proper operation of all bearings. On the top and bottom of both distributor shaft housings are small bearings. Make sure the silver wheel spins freely and smoothly within the black retainer. The bottom of the primary distributor has a different set of bearings than the top and the secondary distributor.
- One shaft at a time, clean and re-lubricate each shaft and its components. Carefully noting how all washers are located, remove all washers and the belt drive sprocket. Thoroughly clean and wipe down all parts and the shaft. Re-grease all parts and reassemble the shaft.

If you have a seized bearing – like I did – you really need to replace it completely. I have yet to replace mine, but I did refurbish it to the extent that I could. If seized, punch out the bearing disc from below. I used brake parts cleaner and some rust buster spray to loosen the bearings. I also had to sand all rust off of the bearing disc. I used steel wool to thoroughly clean and smooth out all parts of the bearing as best

as possible. Once you are satisfied with nice, smooth operation, thoroughly grease the bearings – packing up and underneath each bearing to ensure full coverage. Work the bearings around to verify operation and smoothness. Tamp the bearing disc back into place and again verify that it now spins freely.

## Step 5 – Assembly

You really can't quit now. And besides, you've come this far, you might as well have the fun of now solving this puzzle. It helps to have the base of the distributor in a vice for this process as it doesn't exactly sit in a nice, stable position.

1. Insert the new belt into the base and bolt the case back together with the 5 hex screws.
2. Insert the primary shaft down into the housing and wrap the belt around the drive gear.
3. You can't exactly slide the second shaft – gears, washers and all – into the housing at this point because the belt is in the way. You will need to slide the stack of washers and the belt drive cog off of the secondary shaft and place them inside the distributor body with the belt around it.
4. Notice the notch in the belt drive cog. This is the woodruff key that locks into the shaft of the distributor. That notch is also exactly opposite of the notch in the top of the rotor. So if you have the notch in the top of the primary rotor pointing at the TDC#1 mark on the distributor body, you will need the belt drive cog exactly opposite of the TDC#1 mark respectively. Once you feel confident that the drive cog is lined up properly in respect to the primary shaft, pull it tightly into the belt so it does not slip. It helps here if you insert a screwdriver or pin from below so that the drive cog and all the washers stay put. You'll see why when those washers start sliding around.
5. Insert the secondary shaft into the drive cog and stack of washers that are properly lined up on the belt and down into the distributor shaft. This is not easy and make sure that your wife is not in earshot to hear you cursing up a storm in the garage. You will need to wiggle the shaft around to pick up all of the washers and to get it through to the distributor body – all while not losing the alignment you have on the gear cog. Once you get the shaft fully inserted and locked onto the gear cog's woodruff key, you will need to check alignment again. Insert a pin or screwdriver of some sorts to make sure that both shaft notches are in exact alignment towards the TDC#1 mark. The notched belt helps to some degree – but expect to have to do this a couple times.
6. You can screw the 3 phillips screws back into the primary distributor housing to initially secure the primary shaft from sliding back out and off of the drive belt. Make sure you work the 3 prong cable back out of the body to hook up to the connector plug later.
7. Carefully holding the distributor so that both shafts do not fall out, turn the unit upside down. Reinstall the retaining washer on the secondary shaft. You might need some compression to get enough clearance to get to the groove on the shaft. You might also want to use a punch or a screwdriver blade to make sure the retaining clip fully snaps into the groove. If this retaining clip isn't fully secured, the whole shaft will pull out whenever you try to remove the rotor – not to mention the float during



operation.

8. Reinstall the drive gear on the primary shaft and use a 5/32” retaining pin to secure the gear to the shaft. You will need a clamp to compress the gear to the shaft because of the tension of the washers. You might also be able to insert a tapered punch in one side of the hole to align the gear with the shaft hole and insert the retaining pin from the opposite side. Punch the pin in place and make sure that it has fully mushroomed or expanded to lock into place.
9. Reinstall the black plastic connector to the wire plug and install the retaining clip to secure the connector plug.

You should now have a fully reassembled distributor. Check that turning the drive gear at the bottom of the primary shaft turns both rotor shafts smoothly and accurately – with both rotors properly aligned to TDC#1.

## Step 6 – Reinstallation

You are almost home free now.

1. Insert the distributor back into the engine. Notice how the rotors turn as the gears engage. Make sure that when fully inserted into the engine, the rotors are both pointed to TDC#1 – along with your engine. You might need to pull, turn and reinsert the distributor a couple times to get the right tooth meshing on the gears to get this lined up right.
2. Reinstall the 13mm retaining bolt to secure the distributor.
3. Replace your distributor rotors and caps. (This would be a good time to replace them since you already have them off.)
4. Reinstall the heater blower motor and ductwork.
5. Plug in the connector to the distributor and reinstall the vent tub from the heater duct to the distributor vent.
6. Double-check that everything is properly connected and secured.
7. Check again, including a verification that all plug wires got reconnected in the right order – especially if you replaced caps.
8. Start the car and enjoy all 12 plugs firing.

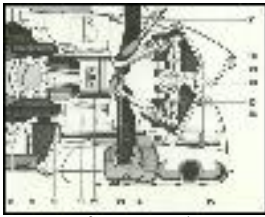

**Figure 1:**  
**Side View of Valve**  
**Train**

## Background

This has perhaps been the most requested technical article of all time here at Pelican Parts. With this in mind, I've decided to throw in a little background into why you would want your valves properly adjusted. [Click here](#) for a complete side view of the 911 engine to refer to. The valves control the volume and timing of the fuel-air mixture that is injected and exhausted from the cylinder head. [Figure 1](#) shows a cut-away view of the valve train. On the first stroke of the piston (#11), the intake valve (#20) opens to allow the air fuel mixture into the combustion chamber. As the piston retreats from the surface of the heads, (travels to the left in [Figure 1](#)) the resulting vacuum sucks in the air-fuel mixture that was provided by the fuel injector (#21). When the piston reaches the end of its travel to the right, the valve is closed, and then the piston begins its compression cycle. The piston travels all the way to the right (in [Figure 1](#)) and compresses the air-fuel mixture. When the piston has almost reached the end of its travel, the spark plug (not visible in [Figure 1](#)) ignites the mixture, and the resulting ignition exerts a force on the piston, pushing it back to the left. When the piston returns to the right, it pushes out the remnants of the explosion (exhaust gasses) through the exhaust valve (#13) which is now open. Then the cycle repeats itself.

The entire cycle requires precise coordination of all the components involved. In the 911 motor, the crankshaft, which controls the motions of the pistons, is tightly integrated with the valve motion through the timing chain. The timing chain runs around the crankshaft and controls the motions of the camshafts (#18) which control the motions of the valves. The exhaust and intake valves are both actuated by a set of rockers (#17 & #19) which open the valves by riding on the camshaft. In their normal position, the valves are sprung closed by the valve springs (#16). When closed, they make a tight air seal with the valve seats that are pressed into the heads.

The timing of the motor refers to the moment in the piston stroke cycle when the air-fuel mixture is ignited. When someone says that they have advanced their timing, they generally mean that they have set the spark to ignite way before the piston has completed its stroke (travel to the right under compression). The reason that you set the timing in advance is because the air-fuel mixture takes a certain amount of time to ignite before it begins to exert a force on the piston.

In general, the amount of time it takes to ignite the fuel is the same when running at different RPMs. As a side note, the octane of the fuel directly affects the time it takes to burn the fuel. The higher the octane, the slower the fuel takes to burn. The term octane (I'm stretching my knowledge of

chemistry here) refers to the amount of oxygenation within the fuel. From what I hear, the oxygenation slows down the rate of burn. In general, the slower the fuel burn, the lower the burn temperature of the fuel within the heads. The term 'knocking' refers to times when the the fuel ignites so fast, that it starts to exert a force on the piston before it has finished it's travel to the right. This force, exerted on the piston as it is finishing its travel, creates the knocking sound, which in general is bad for the engine.

Since the time it takes to ignite the fuel basically remains the same regardless of the RPM of the motor, the motor must adjust to account for the fact that at higher RPMs, the piston is travelling to the right much faster than at idle. In general, as the motor RPMs increase, the timing must advance in order to sync the burning of the fuel with the motion of the piston to the right. On Porsches, there are a few types of timing advances. The most common is the centrifugal advance. Built-in to most distributors is a set of weights that spin around with the distributor rotor. As these weights spin faster and faster (as RPMs increase), they cause a small plate in the distributor to move the points (the small switches that control the firing of the spark) to a more advanced position. In a similar manner, vacuum advance units on

distributors cause a small plate to advance the points based on the amount of vacuum generated by the engine. In most cases, the amount of vacuum generated is somewhat related to the RPM of the engine.

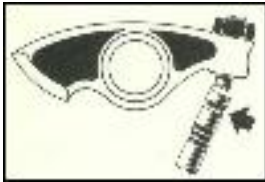

**Figure 2:**  
**Valve Clearance**

Now, back to the valves, and the valve clearances, and why they are so important. [Figure 2](#) shows a close-up of a valve and rocker. The clearance that needs to be adjusted is located between the valve tip and the rocker arm adjusting screw. This screw has a little swivel foot that rotates to meet the valve stem flat. This prevents wear on the tip of the valve. If the clearances of valves are too tight (not enough space), then you can have valves that don't completely close. This can cause leaks through the valves during the motor's compression and/or power stroke, which results in significant power loss, and in some cases can cause engine damage. If the valve clearances are too loose, then you might have a situation where not enough fuel is getting into the cylinder head, or the piston is working extra hard to push out exhaust gases through the narrow opening of the improperly adjusted exhaust valve. Also, valves that are loose are notoriously noisy.

Another good point to remember, and one that is often very confusing, is that a full-stroke of the engine requires two full turns of the crankshaft. The first stroke is the power stroke, combined with the expulsion of the exhaust gases. Then the chamber sucks in air-fuel mixture, and then compresses and ignites it on the second

stroke. This is why the distributor rotates at half the RPM of the engine. It takes the engine two complete turns of the crankshaft to complete one ignition cycle. While the engine rotates 720 degrees, the distributor only rotates 360 degrees.

## **Procedure**

The first thing that you need to do is to prep the car for the adjustment. Raise the rear of the car off of the ground in order to gain access to the lower valve covers. I recommend using jack stands or drive-up ramps to support the car. Do not simply rely on the strength of your hydraulic jack to support the car. This is both foolish and dangerous.

Another important point to make here is that the valves need to be adjusted when the car is stone cold. This means that the car cannot be run for at least four hours prior to you beginning the adjustment. Keep this in mind if you need to drive your car up the drive-up ramps to raise it into the air. I usually let my cars sit overnight before I adjust the valves. I make sure that I jack them up in advance.



**Figure 3:  
911 Valve Adjustment  
Tool**

There are a few tools and parts that you will need. Firstly, you will need a valve adjustment tool. This is nothing more than a small feeler gauge placed on the end of a handle. It's a simple tool, but one that is absolutely necessary for getting into the small spots in the rear of the engine. This tool is shown in [Figure 3](#). It is also advised that you get some extra blades for this tool, as they have a tendency to break, and you don't want to get half way through the job, only to find that you need some more. A normal feeler gauge will not do the job well. You will also need a 13mm socket wrench with a couple of extensions that you will need to be creative about getting the socket into tight places. As for parts, you will need a valve cover gasket kit, and at this time you might want to consider upgrading to the 911 Turbo Valve covers.

Depending upon which car you have (this article is applicable for all air-cooled 911s up to 1989), you may have to remove some equipment from the top of the engine to gain access. If you have an early car with carburetors or mechanical fuel injection (1965-73), then remove the air cleaners to give you some more breathing room in the engine compartment. If you have CIS or Motronic (1973-1989), then remove the



large air cleaner on top of the engine. If your car has air conditioning, you may need to disconnect and slide the compressor out of the way. This is an easy and common procedure. Be sure to wrap the compressor in a blanket to avoid having it damage other items located in the engine compartment. On some cars, there may be some plastic ducting located on the left side, near the blower motor. This may have to be removed as well. Basically, you need to get access to remove the upper valve covers.

There have been some rumors that you should remove the spark plugs when adjusting the valves, as this will make the engine turn easier. Although the engine will turn easier, there is a risk involved with removing the plugs. Very often, carbon deposits that have built up on the plugs and in the combustion chamber can become loose, and subsequently lodged in the valves between the head and the seat while you are trying to adjust them. This would result in an inaccurate adjustment of the valves, and the subsequent poor running of the engine. Wait until after you have finished adjusting your valves to remove the plugs. You can still turn the engine with the plugs installed - it will just resist you a little more.

I also recommend draining and changing the oil. If you are adjusting your valves and performing a major maintenance on the car, it makes sense to replace your oil and filter. Besides, there is a large chance that oil in the bottom sump of your engine will leak



**Figure 4:**  
**Spark Plug Wires**  
**Feeding Through Valve**  
**Covers**



**Figure 5:**  
**Valve Cover Nut**



**Figure 6:**  
**Upper Valve Covers**



**Figure 7:**  
**Lower Valve Covers**



**Figure 8:**  
**Upper Valve Covers**  
**Removed**

out when you remove the lower valve covers.

After the oil has been drained, and the all of the items that would get in the way are removed, the valve covers can be removed. Begin by unplugging the plug wires, shown in [Figure 4](#), that feed through the valve covers. You may want to label the plug wires if you think that you might get them mixed up later on. You should also remove the distributor cap from the top of the distributor. You don't need to unplug the wires from the cap. Now, remove the nuts on the valve covers, as shown in [Figure 5](#). The upper cover is shown in [Figure 6](#), and the lower valve cover (Turbo style) is shown in [Figure 7](#). For clarity, all of the photos used in this article were taken on a motor that was removed from the car. Without a doubt, it is much easier to adjust the valves when the engine is out of the car. The upper valve covers need to be removed from within the engine compartment, and the lower ones need to be removed from underneath the car.

Access to both upper and lower valve covers is normally tight, but you should be able to reach in there with a 13mm socket and remove all of the nuts. [Figure 8](#) shows the cam towers with the upper valve covers removed, and [Figure 9](#) shows the lower valve cover removed.

Now you need to place the engine in Top-Dead-Center (TDC) position for cylinder one. This corresponds to piston number one being all the way near the



**Figure 9:**  
**Lower Exhaust Valves**



**Figure 10:**  
**Fan Pulley Nut**



**Figure 11:**  
**Distributor Pointing at  
TDC Notch**



**Figure 12:**  
**TDC 'Z1' Mark Aligned  
with Case Centerline**

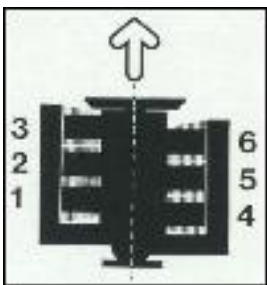

**Figure 13:**  
**Piston/Engine Layout**

cylinder head, and just about to begin the power stroke where it is pushed back towards the crankshaft. Using a large socket on the fan pulley nut, turn the engine fan clockwise. The fan pulley nut is shown in [Figure 10](#). You can also use the pulley holding tool that is normally found in all the 911 toolkits to turn the fan, if your car still has it. The engine crankshaft (attached to the engine fan pulley by the fan belt) should turn easily. If the fan belt slips, then you need to tighten it. Refer to the Pelican Technical Article, [Fan Belt and Pulley Replacement](#) for more details. **Note: it is important that you remember to only rotate the engine clockwise.** Failure to do so may cause damage to your timing chains.

Continue rotating the engine until the distributor rotor is pointing to the little notch that indicates TDC for piston #1. This is shown in [Figure 11](#). Once the rotor is near that point, look carefully at the crankshaft pulley for the marking 'Z1' When the mark 'Z1' lines up with the center line of the case, the motor is at TDC for piston #1. This is shown in [Figure 12](#). When the crankshaft is in this position, the following three things should confirm that you are doing everything correct:

- The crankshaft pulley is showing 'Z1' lined up with the case centerline
- The distributor rotor is pointing at the notch in the distributor housing



**Figure 14:  
Piston/Engine Layout**



**Figure 15:  
Checking Clearances**



**Figure 16:  
Tightening / Loosening  
Retaining Nut**



**Figure 17:  
Adjusting Intake Valve  
with Feeler Gauge**



**Figure 18:  
120° Mark on  
Crankshaft Pulley**

- The intake and exhaust valves for piston #1 should be loose and able to be slightly rocked back and forth.

[Figure 13](#) shows the arrangement of the pistons and cylinders in the 911. Piston #1 is located on the driver side towards the rear of the car. You should be able to 'wiggle' both the intake and exhaust valves, because there will be a clearance there, and the valves will be closed. This is of course, assuming that the motor was running ok before you started to adjust the valves. If the valve clearances are really tight, then there may not be any noticeable wiggle in the valves.

At this point, you are ready to adjust the valves on cylinder #1. For all 911 and 914-6 engines from 1965 the valve adjustment clearances should be:

**Intake: 0.1mm (.0039")**

**Exhaust: 0.1mm (.0039")**

[Figure 14](#) shows the intake rocker arm for cylinder #1. Take the feeler gauge and check the clearance on both the intake and the exhaust, as shown in [Figure 15](#). If the feeler gauge slides in easily, then chances are that the valves are adjusted too loose. Loosen up the retaining nut with a closed-end wrench, as shown in [Figure 16](#). Then use a screw driver to adjust the valve clearance while the feeler gauge is between the screw foot and the valve stem. Tighten up the screw until you feel a somewhat mild resistance on the feeler gauge, as shown in



**Figure 19:**  
**Valve Cover Gaskets**



**Figure 20:**  
**Valve Cover Gasket Kit**

[Figure 17](#). Make sure that you can still move the feeler gauge. Leaving the feeler gauge placed in-between the valve stem and the screw foot, tighten down the retaining nut. Remove the feeler gauge, and recheck the clearance. Again, there should be mild resistance on the feeler gauge. Sometimes the retaining nut turns the adjustment screw and makes the valve clearance tighter than it should be. If this is the case, then loosen up the retaining screw, and readjust as needed. Do this for both the intake (upper, shown in [Figure 14](#)) and exhaust (lower, shown in [Figure 9](#)) valves on piston #1.

After piston #1 has been adjusted, you need to rotate the crank to adjust the next set of valves. Using the socket driver on the fan belt pulley nut, rotate the fan clockwise until the crankshaft moves exactly 120 degrees. There is a marking on the crankshaft pulley that will tell you exactly where 120 degrees is located. This is shown in [Figure 18](#). Don't over rotate; 120 degrees is the same amount of rotation that there is between the 12 and the 4 on a clock. Now you can adjust the valves for piston #6. Refer to [Figure 13](#) for the location of piston #6; it is located on the passenger side all the way towards the front of the car. Check to see if the valves are slightly loose; they should be. If they are not, they may have tightened up, or you may be on the wrong piston. Repeat the procedure explained above. This time you might have to do it blindly, as it is really difficult to see into the front section of the engine compartment. An inspection

mirror might come in handy for the cylinders located all the way in the front of the engine compartment.

After you have adjusted #6, then rotate the fan clockwise another 120 degrees. There should be another notch on the crankshaft pulley. Now adjust the valves for piston #2. Number two is on the driver side in the middle. When complete, rotate another 120 degrees. You should be back at the 'Z1' marking, and the distributor should be pointing away from the notch on the housing. Now, adjust #4.

Repeat the entire procedure above:

- Rotate 120 degrees and adjust #3
- Rotate 120 degrees and adjust #5

After you adjust #5, you can rotate another 120 degrees, and you should be back at TDC for piston number one, and the 'Z1' mark should line up with the case center line again.

Well, your valves should be fully adjusted by now. I usually go back through the motions and just simply check them again to make sure that the clearances didn't tighten up for some reason, or to make sure that I didn't make a mistake somewhere.

When you are finished, you need to replace your valve covers. When you re-install the valve covers, make sure that you use a new set of valve cover gaskets, nuts and washers. [Figure 19](#) shows the

valve cover gaskets, and [Figure 20](#) shows the complete kit with all the nuts, washers and gaskets. It is important not to overtorque the nuts on the valve covers. I was not able to locate a torque specification in the factory manuals, but Richard Lebens found one in the Carrera manuals that says to torque it to 6 ft-lbs. Make sure that you torque them down in a diagonal pattern, and it is advised to start at 4 ft-lbs, and then after all of them are tight, re-torque to 6 ft-lbs.

Make sure that you replace everything that you disconnected, and that you **refill the motor with oil**. Adjusting your own valves gives you more of a sense of ownership of the car, and also helps to cut down on those expensive maintenance bills that are typical of Porsche ownership.

After you have done this a few times you will recognize that there are a few tips and tricks to adjusting the valves. Firstly, instead of turning the crank 120 degrees, you can turn it 240 each time, and adjust each set of valves on the same side. You will eventually have to turn it 120 degrees to get it started on the other bank of cylinders. Also, after a while, you will be able to adjust the valves just by looking at when they both close. This is known as adjusting 'by feel' and is quite easy once you get the procedure down the first time.

Well, that's about all there is to it. It's really not that difficult if you follow the steps carefully, and make sure that you double-check your work.

# 911 Motor Rebuild Overview

The purpose of this Tech article is not to provide a step-by-step guide to rebuilding a 911 motor. There are complete volumes of Factory manuals on this subject as well as a multitude of books and other written material that cover the specifics of engine rebuilding. This article is simply a collection of my own personal experiences and tips meant to aid in understanding various aspects of a rebuild. It is my hope that this article will become one of many tools used by the determined DIY'er as he/she prepares to rebuild a 911 motor.

I am going to assume that the decision has been made that the motor in question is in need of a total rebuild. In my mind, the first thing to do is to collect as many 911 books and manuals as you can get your hands on. There are many good books available including Bruce Anderson's "Performance Handbook", Bentley Publishing's "Porsche 911 Service manual", the Haynes "Porsche 911 manual", Wayne Dempsey's "101 Projects for your Porsche 911" ([Link](#)) and of course the applicable volumes of the Porsche "Factory Repair manuals". Reading books will only get you so far. I found that it was almost impossible to completely understand how some things worked until I actually had the pieces in my hands.



If you aren't scared away from what you have read in all those books you bought than it is time to start gathering the proper tools that will be needed to remove, teardown, and reassemble the motor. In Bruce Anderson's "Performance Handbook" there is a good list of required and specialty tools that will be needed to rebuild an engine. I am going to assume that the person attempting to rebuild his/her motor is at least a competent weekend mechanic with a good workspace and common hand tools. Next, I suggest you start buying the parts that you "know for a fact" will need to be replaced during your rebuild. This includes, above all things, a quality Rebuild kit (available from Pelican). Don't go the cheap route on this; you'll need a good kit. Plus, you need to be aware there will inevitably be many parts that will need to be replaced and that some of these things you will not be aware of until you have cleaned and inspected the parts. (Such as burnt valves, worn guides or intermediate shaft gears) ... Budget for this!

This article will be broken down into 5 main sections:

**Removal, Teardown, Inspection, Reassembly and Break-in.**

## **Removal**

Removal of the engine is covered in detail in [Pelican Parts Tech Article on Engine Removal](#).

Personal Note #1: it is a good thing when you DON'T drop your engine when trying to remove it from the car. ...Trust me.

## **Teardown**

Once the engine is out of the car (hopefully via "Controlled descent") you need to get it off the floor and onto an engine stand. Before you can fit the engine to a stand, you will most likely have to remove the clutch and flywheel. Removal of these components are covered in [Pelican Parts Tech Article on Clutch Replacement](#).

You can buy the Factory Engine stand (very expensive) or get a generic engine stand from your local NAPA store and modify it to fit the studs on your engine. I managed to modify a cheap \$75 dollar stand by cutting the mounting tubes down on the arms to fit the shorter studs on my engine. With a bit of imagination it is possible. I was lucky enough to have access to an engine hoist, which I used to lift the motor off the floor and onto the stand. I found it much easier to mount the face of the engine stand to the motor then lift the engine up with the hoist and slip the yoke into the stand. If you get this far in one day it's time to stand back and drink a beer.

Now that you have the motor on a stand it's time to get started with the real fun stuff.

Have a collection of assorted size Ziploc bags and boxes of all shapes and sizes in a holding pattern next to your work area. I suggest using a small notepad and disposable camera for taking notes and photographing pieces and parts as they are removed. Be absolutely sure to group, label and separate all parts removed.

Personal Note #2 One thing most books don't mention is the fact that when you receive your new Rebuild kit, it comes as a box full of gaskets, o-rings, washers, seals,

chains, piston rings and other misc. items. On the one I bought, nothing was labeled. It is not fun trying to figure out where two- dozen different sized o-rings go to unless you saved the old o-rings as you removed the parts. So, my suggestion is to keep all of the old gaskets, o-rings and other seals with the parts as you remove them. That way, when it comes to reassembly, you can take an old o-ring and dig through the rebuild kit until you find it's new counterpart. If I had thought of this ahead of time, it would have saved me allot of trouble.

The first thing to come off will be the induction system. Whether it be Carburetors, MFI, CIS, or DME, they all basically come off the same way. The intake ports on each cylinder have two 13mm nuts on them. Some of these nuts were almost impossible to get at with a wrench! On my SC, there were a few that required some pretty ridiculous combinations of drive extenders and universal attachments as well as stubby open-ended wrenches. Best advice I can give you is: "Good luck... It isn't fun." My injection system experience is limited to that of my '79 SC so I can only give specific information applicable to the K-Jetronic cars. I removed the entire fuel system from the motor as one unit. I unbolted the intake runners, disconnected and marked all fuel lines and wiring harnesses and pulled it off.

The removal of the engine mounts, tin, fan/alternator and ancillaries is pretty straightforward. Just make darn sure you take pictures and mark the alternator wires!

The exhaust system turned out to be a bigger job than I originally anticipated. When people say: "Yup, those exhaust studs normally rust up and freeze solid"...they aren't lying. I squirted the nuts with WD-40 and let them sit for a couple hours while I ate lunch. Personal Note #3 I found that instead of buying the "Super Special Porsche Factory tool" to remove the exhaust nuts, that an 8mm T-handled Allen wrench with a breaker bar fitted onto one end for leverage worked like a champ.

Some people suggest using a torch to heat cycle the exhaust nuts several times before trying to remove them. I didn't have the luxury of having one available so I just let them soak in WD-40 and gently tried backing them off. I was successful at getting them all off without incident except for one, which snapped. It really didn't matter though because all of them were severely corroded and pitted so I decided from the get go that they would need to be replaced when the cylinder head work was performed.

With the engine shroud removed, you now have a long block! (Time for the next beer)

No more kitty stuff, now we're getting into the Meat and Potatoes of this baby!

Everybody knows that taking apart an engine isn't exactly brain surgery.... It's puttin' it back together and having it run which is the tricky part. I won't get too specific about what comes off next and in what sequence. There are obviously several ways to do the same thing.

The next parts that must to come off are the cam chain housings. (Image) Once you get the tensioners out and the cam gears taken apart (special attention is needed here to keep all the tiny parts organized) you can sit down and remove all 12 rocker arms and

shafts from the cam housings. These little suckers can be a pain in the butt. Calling them stubborn would be too nice. Let them soak in WD-40 for a couple hours; I found that it helped a bit. (Remember to properly label each rocker arm with its shaft,- i.e. #3 Intake) Once the rocker arms are removed than you can slide the cams out of the cam housings. Be careful when doing this, the cam housing is made of aluminum, the camshafts are steel, if one of them binds as you are removing it don't be too rough, you could damage the softer aluminum housing.

With the cam chains out of your way you can now remove the cylinder heads and cam housings from each bank as one unit. I found that this was the easiest way to do it.

Personal Note#4 I discovered that you don't have to buy the Super Special 10mm Porsche tool for removing the head stud nuts. A common Allen head socket on a drive extension worked like a champ.

When you remove the head stud bolts, do it in an even, progressive manner. You don't want to possibly warp the cam housing. Once the cylinder heads have been removed you should be staring at the tops of your pistons! (By now you should be very excited)

Remove the air deflectors and oil return tubes and bag 'em up.

Using a soft mallet, gently tap on the base of the cylinders and they should slide right off without too much of a fight. I put rags underneath the exposed pistons to keep them from flopping around against the head studs and possibly damaging them.

If you have an early engine, remove the oil sump plate cover, thermostat, breather housing and engine mounted oil cooler. (treat the oil cooler as if it were made of gold...it's almost worth its weight in it!) Now you should have an engine block with pistons sticking out of it.

Personal note #5 I found out the HARD way that you MUST remove the pistons from the connecting rods before you attempt to split the case. "DO'H!!" At this point it is easy to get a little ahead of yourself with anticipation. Remember to take it slow and steady.

As far as removing the pistons goes, the most important thing to remember is that when the piston wrist pin cir-clips come out of their groove, they can do so at Mach 6.5. Be careful!

Use a hardwood dowel to drive the wrist pins out. You don't want to put a heck of allot of cross load on the connecting rods so don't spank them too hard!

Mark the location of each piston and bag them. Now you can spit the case!

Turn the engine on its side and remove the butt-load of nuts securing the case halves together, including the crankcase through-bolts. Don't forget the ones that sit behind the flywheel, they could be covered with gunk and overlooked. This next part is tricky to say the least! I used a soft mallet and a large screwdriver to "coax" the halves apart. I did not force the screwdriver into the seam and "drive" it open. That will definitely damage the sealing surface. Rather, I used the mallet to get the case to start to separate and once I had a small gap going, I used the screwdriver to gently spread the halves. It takes quite

a bit of jostling. Once it comes free, lift it away and take a beer break...you'll need it.

Now the crankshaft and connecting rods may be lifted away. To remove the oil pump and lay shaft you need to break or bend the small Lock-tabs that secure the pump to the case. Pull it all apart, bag and label everything. Mark all of the main components with their respective numbers.

Congratulations! You have just completely torn apart a 911 motor! Now you have to put it back together... oh boy.

## **Inspection**

Inspection of components is where the expensive manuals you bought will come in handy. Understand that there are some parts that require special tools or professional equipment and expertise to properly inspect for wear and serviceability. Clean everything thoroughly. (A solvent tank is very nice to have.) I knew that some of the parts would be waiting a while before I got to refit them, so I put a thin coat of oil on things like the cams to keep them from rusting and wrapped them up in rags. Depending on what you have discovered up to this point you can determine what work needs to be completed and which parts will need to be replaced. For instance, I found that the intermediate gear on my motor was quite worn. (Image) It was still in spec, but just barely. I decided it didn't make much sense to reinstall a part that was just marginal so I bought a new one. I did the same for the chain gears.

There are many good Machine shops out there who specialize in Porsches. They can handle all of your cylinder head and balancing work. The bottom end of 3.0-liter engines are amazingly tough. My main bearings looked almost brand new (With 220,000 miles on them). Some people use the 3.0 liters reputation of being very sturdy to avoid tearing apart the bottom end. I personally disagree with that because although the main bearings looked great and the rod bearings looked ok, the lay shaft bearings were almost totally shot. They were worn into the bronze. Second point, by the time you've got the motor out of the car, disassemble and clean the top end, you've already done 80% of the work. Why not split the case and throw a new set of bearings in there. It's really not that much more work!

I had my crankcase, cylinder heads, and cam housings Hot Tanked by the local NAPA store. If you take your parts somewhere to be hot tanked, just make sure they have a separate Hot Tank for aluminum parts. The Hot Tanks used for cast iron blocks will melt or damage aluminum parts. Personal Note #6: Make sure you remove the two Oil pressure relief valve pistons and springs located on the lower left and bottom sides of the crank case. I would also strongly suggest you replace the springs. They only cost a couple of bucks apiece.

## **Machining**

I sent my crankshaft out to be checked for cracks, inspected for wear, and micro polished to finely polish the wear surfaces. I had my connecting rods checked over, new wrist pin bushings installed in the small end and had the big ends machined back to their proper size. The rods were precision balanced with their respective pistons. I also sent

the machine shop my new flywheel and pressure plate so that they could be balanced with the crankshaft. Next I sent them my old rocker arms. The bushings were pretty worn and I was lucky enough to find a supplier who got a shipment of rocker arm bushings so I had new bushings installed and honed to fit new rocker arm shafts. Porsche builds some pretty good little engines. The machine shop I used was fairly impressed with how close the parts were (from the factory) in terms of tolerances and wear.

I sent my Cylinder heads to another machine shop who specializes in Cylinder head work. They disassembled and cleaned the heads, installed the new valve guides, valves, springs and keepers I bought and shipped me back a set of shiny new looking heads. I also sent my engine mounted oil cooler out to be ultrasonically cleaned.

## **Head studs**

This stage is a good time to replace the head studs if any are broken. Almost everybody has a different opinion about the head stud issue. On my engine, I was rebuilding it due to a broken bottom stud on the #6 cylinder. From what I have been able to tell, on 3.0-Liter engines, the bottom studs are prone to breaking. The bottom studs are made from a material called Dilvar while the top row of studs are made of steel. Most people seem to think that years of exposure to the elements and countless heat cycles make the Dilvar studs weak and brittle.

I decided to only replace the bottom 12 studs. I ordered a set of the factory steel studs and installed them myself. In order to get the old ones out of the case you need to borrow your beefy neighbor for a bit. Some people suggest gently using a torch to heat the base of the stud in the case to melt the Loctite that was used when they were installed at the factory. I didn't like the idea of putting a torch to my precious case so I just went with careful, brute force. You can either use Vice grips, double locked nuts, or a special built stud remover available at most specialty stores. Since I didn't remove the top row, I was able to install the bottom studs to the same height, measuring off of the top stud. I used a high strength Loctite to secure the studs in the case.

## **Reassembly**

Once all the rotating parts have been cleaned, measured, machined, repaired or replaced, it is time to begin reassembly. The bottom end is actually quite simple to reassemble. The biggest hurdle is having everything laid out in a neat, logical order. You need to have all the tools, parts, and other items set out in a way that you can work things methodically and quickly at the same time. (I say quickly because you only have a set amount of time to seal the case before the Loctite used between the crankcase halves begins to harden.)

## **Crankshaft**

When I assembled the connecting rods to the crankshaft, I lightly oiled the rod bolts and evenly torqued the bolts in steps to their proper torque. Some manuals say to torque the bolts to a certain torque, and then turn the wrench 90 degrees. I didn't like that idea; it just didn't make sense to me. But as with almost anything automotive, there are

several methods that can be used which achieve the same goal. I also installed my crankshaft with the flywheel main seal installed.

## **Crankcase prep**

Once the crank and rods are assembled, you can install your new main bearings in the right crankcase half and lightly oil them with assembly lube/motor oil. Gently lower the crank into place with its nose bearing and new o-ring installed. Make absolutely sure that the nose bearing is aligned with the dowel pin on the crankcase. If it is not, then it will not seat and you'll have one big mess on your hands. After I had my case hot tanked, I noticed that the dowel pin was missing on my case half. I called around to see what I should do and a very reputable source who shall remain anonymous, (John Walker) suggested that I take an old drill bit of equal size, cut off a short length at the base and use it as a makeshift dowel pin. I used a mallet to set it in the hole and it worked like a champ!

Once the crank is correctly seated in the case half, then it is time to install the lay shaft and oil pump (as one assembly). (Image) Don't forget to put the new timing chains around the gears before lowering it into place! You will need 3 new lock tabs to secure it to the case. My rebuild kit didn't come with any and it set me back a week waiting for three little dinky lock tabs to arrive before I could proceed. Remember to lube and carefully install the o-rings that seal the oil pump into place.

Now with the crank, lay shaft and oil pump in place it is time to begin preparation to lower the other half of the case onto the first. This represents several small problems to overcome. First, you have three connecting rods that are flopping all over that need to stand straight up to go through the cylinder spigots on the left crankcase half. And you also now have one of the timing chains dangling about. This is one of those steps where it is almost as if you need six pairs of hands to hold everything. I used a stiff piece of cardboard cut into a strip to support the chain straight up in the air (Image). And as for the connecting rods, I used masking tape to hold them up (Image). (This is where the methodical, neurosurgeon attitude comes into play.) Now that you have everything secured and out of the way, it is time to place the other half of the case into position. Install the main bearing shells (correctly) and lightly lube them. Gather up all of the nuts needed for the case perimeter and the socket wrench to tighten them with. Pre-assemble the crankcase through-bolts with their new o-rings and lube them up with Dow Corning 111. Have your trusty Torque wrench set to the proper torque standing by. The next step is to put a bead of sealant, whether it be Loctite 574 or an equivalent, around the sealing surface of the case. I must say, I thought this was pretty straight forward and not hard at all. I do however have an oil leak on my rebuilt engine coming from the area immediately around the crankshaft nose bearing, behind the fan pulley. I don't now if it is because I used too much Loctite, or too little, or if there was a slight burr in the surface that I didn't notice. At any rate, there is nothing I can do about it, but I want to stress the importance of closely inspecting the sealing surfaces for any gouges or burrs, or anything at all that could lead to a poor seal.

Immediately after you get a thin, even coat of sealant around the sealing surface it is time to lower the left case half into place. It is really handy to have a helper at this point.

I had a friend help me lower the half into place, all the while making sure that the timing chain and connecting rods weren't hung or fallen out of place. I used a mallet to gently tap the case halves together and immediately started hand tightening the multitude of 13mm. Perimeter (crankcase flange) loc-nuts. As my friend was busy fumbling with the loc-nuts, I was busy installing the crankcase through-bolts, complete with lubed o-rings, in their respective places. The through-bolts are the first to be torqued. I torqued them in stages and in a criss-cross pattern. Once you are satisfied that all of these have been torqued (including the two behind the engine mounted oil cooler and one in the left chain opening) then you can proceed to torque the crankcase flange bolts. Once all of this is done it is definitely time for another beer. Congratulations you now have a completed Bottom end!

## **Pistons and Cylinders**

Here is another topic of great debate. Porsche used two suppliers for its pistons and cylinders, Mahle and Kolbenschmitt (KS). The Mahles cylinders use a plating process in the bores lined with a material called Nikasil. While the KS cylinder bores are impregnated with a substance called Alusil. The Mahles have a rock hard nickel-plating while the KS cylinders are impregnated with a kind of silicon. In my opinion both are well made but most people tend to think that the Mahles are the superior brand. You can tell if you have the Nikasil cylinders if the bores are very shiny and reflective. They also have "MAHLE" cast into the base. The KS cylinders are not near as shiny and have almost a yellowish tint to the bores. As of yet, no one has ever been able to tell me if there is some sort of rhyme or reason to the way Porsche chose to use the different types of pistons and cylinders (P/Cs). My personal guess is that Porsche used whichever pistons and cylinders they could get their hands on at the time so that is why you never know which type you might find on your car.

On horizontally opposed engines such as the 911, the cylinder bores have a tendency to wear in an oval, making them out of round. If you try to re-ring the pistons and slap it all back together with even slightly out of round cylinders, I have been told that you run the risk of having the new piston rings dig into your cylinder bores and you could end up with broken rings very quickly. If you are lucky and your piston skirts and cylinder bores are still within factory tolerances, you may still be able to use them. After asking many shops, Porsche-gurus and one certain pillar of the Porsche community, most of them seem to think that you can get away with roughing up the bores a bit using a scotch-brite pad to help the rings seat and put it all back together. But others have told me that they have tried this method and although they said to have had some success, one in particular said that if a customer wanted him to do that then he asked them to sign a statement saying that the motor may smoke more than usual. Well, I didn't like the idea of my brand new motor smoking as I drove down the road so I looked for other options.

One of the other options includes, buying a set of new pistons and cylinders. Obviously this would be the best route to go but I simply could not afford to spend \$2500 on pistons and cylinders. So, I kept looking for other alternatives. I found a place in Reno, Nevada who offered a "reconditioning service". They have the ability to re-size and re-plate the Mahles and re-impregnate the KS cylinder barrels using some pretty

advanced methods. Both of these services are much cheaper than buying new pistons and cylinders.

My car originally had Mahles installed but I ended up putting a reconditioned set of 9.3:1 CR, KS pistons and cylinders in my motor.

Bottom line is that there are many different options out there, but you must decide how much you're willing to spend and what risks you find acceptable.

When it is time to install the pistons and cylinders onto the assembled bottom end, there are a couple ways to do it. I, being a novice, did what most novices probably do, which was mount the pistons to the rods then try to slide the cylinders over them. This proved to be the biggest pain in the rear of the entire rebuild. What I now suggest, is to take a piston and cylinder on a workbench, install the piston rings, compress the rings, slide a barrel over the piston just enough to cover the rings, then take the whole thing and slide it over the head studs on the case, drive the wrist pin into the piston and then squarely tap the cylinder into place. (Do not forget to install a new cylinder base gasket before installing the cylinders!) For some odd reason, I have read that some books tell you to make sure to only use new wrist pin cir-clips and to ensure that they are facing (open end) either towards or away from the connecting rod. I can't imagine why, but I did it anyway. Also, before pressing the cylinder to the case Double check that you didn't forget to install a cir-clip on both sides of the wrist pins.

Personal Note #7In order to get to all of the connecting rods you must spin the crank over to get each rod at TDC (Top Dead Center). When you do this, the cylinders might try to move away from the case due to the resistance from the piston rings. You can buy the Super Special Porsche Cylinder Holding Tool, or you can take two head stud nuts, thread one all the way past the threads, up against the cylinder and tighten the other one down right behind it. Worked like a champ. I can't even believe they" made" a special tool for this job! Remember that when you try to rotate the crank that the two timing chains can bind on themselves really easily. You might think that there is a problem because your engine won't turn over but it's most likely just one of the chains or one of the loose connecting rods catching on something because they are loose.

## **Heads and Cam housings**

I am not going to get into too much detail about the actual assembly of the heads. When you send them out to most machine shops they reassemble them for you as part of the job. Again, there are several ways to go about doing this and everyone has their preference. You can bolt the individual heads to the cam housing on a workbench then mount the whole assembly on the engine, or you can loosely bolt each individual head to its cylinder, place the cam housing on top of it and bolt everything down. The most important thing to remember is that whatever you do, you want everything to be evenly tightened to prevent any warping of the cam towers. The best way to check for warping that might be occurring as you tighten the cam housing and head bolts is to temporarily install a cam shaft and constantly turn it while you tighten the bolts. If any resistance is felt in the rotation of the cam then stop, back off and try tightening it in a different order.

With the heads, cam towers, crankcase breather housing, thermostat, cam chain



housings and oil cooler installed you almost have a completed long block! (Don't forget to fit new oil return tubes into the case before attaching the cam housings!)

The dreaded Cam Timing - Yes, we are finally there!

I was just as confused and worried about the cam timing as every other 911 rebuild virgin. I must say right now that even though it is a tedious task that must be done right, it is not that hard at all once you understand what you are trying to accomplish. Trust me, if I can do it than you can do it too!

Before the cams can be timed it is necessary to install the intake rocker arms on the #1 and #4 cylinders. Refer to the [Pelican Parts Technical Article on 911 Valve Adjustment](#) for complete details.

First off you must understand the basic idea of how a 4-stroke internal combustion engine operates. Hopefully you already understand this before you completely rip apart your engine! Bruce Andersons "Performance Handbook" has a very good section, which gives a detailed description of how and why valve timing is so important. For sanities sake I will not go into a step-by-step detail about the cam timing because it is covered in such detail in every manual out there. I would like to give an explanation of "what your trying to do" in normal language to hopefully clear up a bit of what the manuals don't get across too clearly in my mind.

First it is necessary to "Rough time" the engine. Rough timing of the engine is accomplished by eyeballing the position of the camshafts in relationship to the crankshaft. First thing to do is to turn the crank to TDC. That means (in theory) that the #1 and #4 cylinders both have pistons at their full extension. So, how do you get the #1 cylinder to TDC? Simple, first Install the crankshaft pulley on the crankshaft. Notice that there is a dowel pin that dictates how the pulley goes on the end of the crankshaft. You can't mess it up; it'll only go on one way. Now, on the face of the pulley there are 3 marks, one of them has "Z1" marked next to it, that is your TDC mark. So, simply rotate the crank until the Z1 mark is matched up with the seam in the crankcase. (There is also a notch in the bottom of the fan shroud if you have it installed.) Once these are lined up your crankshaft and pistons #1 and #4 are now at TDC.

I found that the best way to figure out which stroke the cylinder is on (compression or firing) during this whole process is to install the distributor and use the rotor as a guide. To set the distributor to #1 firing stroke is easy. Simply set the crank to TDC, get the distributor shaft started in the hole (with new o-ring installed of course) and roughly point the rotor where the #1 spark plug wire would normally go into the distributor cap (if it were installed). The rotor should be pointing at something like a 45 deg. angle up and away from the engine. When you seat the distributor fully into the case, the worm gear on the crankshaft meshes with the gears on the distributor. It takes a bit of playing with it to get the rotor to point in the proper direction. The [Pelican Parts Tech Article on Setting Static Timing](#) gives a detailed description of how to set the distributor.

With the distributor rotor pointing as described, the engine is now at #1 TDC firing stroke. If you were to rotate the engine 360 deg. at the crankshaft, from this point, the rotor would now be pointing 180 deg. from where it was. And now the engine is on #4

TDC firing stroke and #1 in at TDC compression stroke. If you understand these two things than you can time an engine.

Once the cams are installed and have been sealed to the cam chain housing you need to get them roughly pointed in the right direction. (Image) On each cam there is either a number or a dot stamped on the face. This number or dot must point up. With the cams pointed up (chains not attached) and the crankshaft at TDC, your engine is now rough timed.

Now that the motor is rough timed, assemble the gear flanges with the woodruff keys on the cams and install the gears on the cams with the chains.

The cam gears are kept in position by the use of the little dowel pin that locks the gear flange with the gear. There are 17 holes around the circumference of the gear. When you are timing the cams, you are doing so using a method that measures the amount of overlap of one valve on each bank of cylinders. These measurements are taken with the use of a dial indicator on a special "Z" mount. (Fortunately you can pick up a dial indicator for around \$30 or so and I believe Pelican carries the indicators and the Z mount. I would suggest buying a Metric dial indicator; it makes the process much easier without having to do conversions.)

You are attempting to set timing on one bank of cylinders at a time. Starting with the left bank, position the dial indicator with about 10mm. of preload so that the indicator needle is resting on the cylinder #1 intake valve cap. When you have the crank at TDC and the left banks camshaft pointed up, and the dial indicator set on the valve cap, you are ready to time the cam on the left bank. (You can either install the tensioners at this stage, which is what I did, or you can use a long screwdriver to keep pressure on the idler arm, which will keep the chain tight.)

With everything ready to go on the left bank, insert the small dowel pin into whichever hole is lined up (It'll make sense when you see it) and hand tighten the large nut and washer. While you tighten the nut you don't want the cam to move even the slightest bit. Once you think you have it set as best you can by eye, you turn the crankshaft exactly 360 deg. while watching your dial indicator. (In your manuals it will give you a certain value of overlap in millimeters for your specific motor and camshafts; for my 3.0 it is 1.55mm.) That's what you are trying to get on the dial indicator. If, after spinning the motor exactly 360 deg., you get a reading higher or lower than what is called for, then the dowel pin will have to be removed and relocated to another hole. This is more less a trial and error process. It took me several times to get it down right. When you can rotate the crankshaft 360 deg. and get the exact value that is needed that bank is now timed properly! All you have to do is torque the nut and re-check to make sure nothing moved. Now you just move on to the right bank of cylinders and repeat the whole process.

(Remember that when the crank is set to "#1 TDC firing stroke", if you rotate the engine 360 deg., that now even though the crank has made one complete revolution, you still need to turn it another 360 deg. to get back to your starting point of "#1 TDC firing stroke". It takes 720 deg. (two complete revolutions of the crankshaft) to get from #1

firing stroke to #1 firing stroke again because it is alternating with the #4 cylinder.)

There is a little more to it but the repair manuals break it down pretty good. Just be absolutely sure to double-check your work before moving on. Next, it is time to install the rest of the rocker arms and shafts in the cam housings. This was a bit tricky because you have to center the rocker arm shafts in the camshaft housings. The rocker arm shafts are held in place by the use of a pinch bolt. There are cone shaped pieces that fit into each end of the shafts and when you tighten the bolt it draws these two cones towards each other causing the ends of the shafts to flare just a bit. This flaring action is what secures the shafts in the bores. I bought a set of RSR o-rings that were used by the factory on racing engines. These little o-rings sit in the grooves on the rocker arm shafts and provide a bit of extra sealing protection against oil leaks from around the shafts. I think they are a pretty good idea, especially for the price. After you torque each rocker shaft into place, wiggle the rocker arm back and forth to make sure that it moves freely. If it binds than the shaft is off center and must be corrected. I found that the shafts were pretty close to center when the flared nut was just about flush with the narrow side of the cam tower. The next order of business is to perform a precise valve adjustment. Again, this procedure is explained at length in pelican Parts Tech Article on 911 Valve Adjustment. (Link) Pat yourself on the back and go kill a six-pack because you have just completed a long block!

### **Injection System, Exhaust, Ancillaries**

The majority of the remaining work is simply “reverse of removal”. From this point on, everything should really speed up. The exhaust system is pretty simple, the only hard part is figuring out a way to get a wrench in some of the incredibly tight places under there! Remember to use only new gaskets and put a bit of anti-seize on all of the stud threads.

For CIS cars, refitting the injection system is not all that hard. I really didn't disassemble mine beyond the intake runners. I fitted new rubber boots, vacuum hoses, warm up regulator, cold start valve, thermo time switch, injectors and o-rings and cleaned up the air box and metering plate real well. It worked fine before I removed it so I figured it was better not to mess with it any more than I already had.

Those notes and photographs you took when you removed everything will be invaluable at this stage. Trying to remember where all those vacuum hoses, fuel lines and wiring harnesses go is not fun if you didn't label and take notes of their locations before hand.

Once you get the exhaust, intake, fan/alternator, plug wires, engine tin, engine mounts and cross bar re-installed you are on the home stretch.

Getting the engine back in the car is a tricky bit as well. When you have the engine assembled to this point, you can't do anything further on the engine stand. I fabricated a wooden dolly mounted on casters to set the engine on. Now that you can roll it around and without the engine stand in the way, you can now install the flywheel and clutch. When installing the clutch and flywheel remember to properly center the friction pad with a centering tool (Image) before you tighten down the pressure plate. And, pack the

pilot bearing on the flywheel with heavy grease to keep it well lubed.

It is now about time to prepare the car for installment of the new engine. A good cleaning of the engine bay will make things go smoother. I drained the gas tank since it had been sitting for almost 9 months. I then filled the tank up with premium Techron and charged the battery. Once the battery was charged I put a bucket under the fuel hoses in the engine bay and turned on the ignition to pump the old gas out of the fuel lines. Once new gas started coming out I was satisfied. I had the advantage of using a car lift to raise my car in the air. Then I rolled the engine on the dolly under it and v e r y slowly lowered it towards the engine. (Image) I had a helper who kept an eye on things and moved the motor around a bit while I lowered the car even lower. The biggest problem I encountered was the fact that there just wasn't enough room under there to try to mate the engine up to the gearbox, which was still in the car. If I have to ever do it again I will remove and install the engine and gearbox as one unit instead of shoehorning it like I did. It was next to impossible to squeeze myself under there and wiggle the day lights out of the engine while raising and lowering the car mere millimeters, countless times trying to get the studs on the engine to mate up with the gearbox and getting the throw-out bearing release fork to engage the TO bearing. I still think it was a miracle that we ever got it all together. I will never do it that way again.

Once we got the motor bolted to the transmission, I lowered the car until I could attach the engine mount bolts near the bumpers. From there it was simply a matter of reattaching the throttle linkage, clutch arm and cable, oil and fuel lines and wiring connectors. After topping it off with fresh oil and I was ready to try and start it.

### Break-in

The first few seconds that a rebuilt engine runs it has very little lubrication and no oil pressure. These first few minutes might very well be the most abusive moments your engine ever knows. When I was ready to start my engine I first, disconnected the fuel pump relay, (to keep gas from the engine) then pulled the ignition wire out of the Voltage transformer also known as a coil (to keep the engine from sparking). Then I hopped in the car, crossed my fingers and gave it a whirl. I cranked the engine with no gas or spark about 5 times at 6 or 7 second intervals; until I saw my oil pressure gauge move. When the gauge needle moved I knew that oil had been circulated throughout most of the passages in the motor. Next, I re-installed the fuel pump relay and cranked it several more times to get fuel into the fuel lines. After a few seconds of this I connected the plug wire and gave everything a once over, triple checking that I didn't miss anything I closed my eyes and turned the key.

I must have cranked on that thing for 15 minutes. I got nothing, not even a blip. I started pulling fuel injectors and found that they were all dry. I knew the fuel pump was running and that fuel was getting to the fuel distributor so I was puzzled as to why it wasn't getting past the injectors. After a bit of reading I discovered that CIS injectors are designed to open at a certain amount of pressure. I wasn't getting enough fuel pressure to open the fuel injectors and I couldn't figure out why. After another 10 minutes of periodic cranking the engine started showing signs of life. Every time I cranked it, the motor started sputtering a little longer and longer until finally, she roared to life!

# 964 Rear Blower Motor Replacement

---

Sooner or later you are going to have to replace the blower motor that is located in the right side of the engine compartment. One day you will start the car and think that have a cat caught in your fan because of the noise.

Don't despair, this is an easier (and cheaper!) fix than you might think at first. Porsche has discontinued the original blower motor for the 964's and they have replaced it with the 993 version (993-624-328-01). This is the exact same fan and for the \$115 you pay Pelican Parts for it you get the complete assembly – motor, housing everything ready to pop in and drive away.

Well ALMOST !

There is one small problem. The 993 assembly is just a little bit different The bushings that the mounting bolts go through to mount to the intake manifold are a little longer than the 964 ones. It will go together (barely – with force) and look OK (if you can live with a ½ gap at the fan housing), but it is so much easier to do this right.



This is a diagram of the blower motor assembly. There are two bolts located on the right side of the unit – one in front and the other you will have to feel around a little to find under the fan. Remove the bolts and disconnect the wiring leads to the blower and the resistor. You will also need to disconnect the hoses to the distributor and rear light vents then loosen the band clamps at the top and bottom of the tube that the resistor is mounted in.



Wiggle the assemble to loosen the boot connection to the engine shroud and remove it from the engine.



At this time you might want to ensure your resistor was replaced in the PO2 recall. The old resistor is p/n 964-616-550-00 or 01. The new resistor is the same number except -02.



The two motor assemblies are identical with the exception of the bushings. Here they are side by side.



You will have to take the screws out of the housing to get to the bushings to swap them out. Just remove all of the screws around the outside edge and the motor section can be pulled away. After you do this to the old unit (in case you screw anything up – you do it to the old unit !) Do the same to the new unit



Take the bushing out of each of the units and install the shorter ones into the new fan housing. Assemble the unit and reinstall into the car.



The difference between the bushings doesn't seem to be that critical, but it will cause you major headaches later when you try to install the assembly. The longer bushings hold the entire assembly away from the mounting pads (located on the intake manifold). You cannot get more than 1 turn of the bolts into the pads and you can EASILY strip out the mounting pads.

I could not figure out what was wrong when I did this because everything SEEMED to be together except the bolts did not go in as far as they were and the duct going to the engine fan housing was off just a little. The next day, I checked to see that everything was still OK and I found the front bolt had come out and the unit was not connected to the engine fan housing (see circled areas).

I took everything back apart and realized the only difference was the bushings and when I tried to bolt them to the mounting pads, I could only get a single turn of the threads to engage – obviously not enough. I tried the old bushings and everything went together just like it was before.

It is a statement about the precision of these cars that a small difference in the bushings keeps all of the other parts from lining up correctly OR you could say it is a sign that Porsche should do their homework on replacements a little better. They must have been sidetracked by the SUV !

---

# 964 White Gauge Faces

Most of the time when you do an upgrade to your car it is on the exterior, engine, or under the car, so when your driving you don't really get to appreciate it as much as others who can see it from the outside (or hear it).

Here is a project that you will be able to enjoy every time you get in your car.

Replacing the gauge faces with ones of another color is a personal choice as there are some that feel this is changing the originality of the car, but it is YOUR car so do what makes YOU feel good.

In my case, the combination of the Grand Prix White exterior and black interior was very nice, but it needed a little something extra to make it really contrast and bring the interior to life. In this case I did what I had done on my 74 targa, I changed the gauge faces to white ones.

On the 74, I took this project on as a do it yourself one. Taking the gauges apart and changed the faces out myself. It was a difficult, but a very rewarding project.

This time I decided to have North Hollywood Speedometer do them for me. Doing it once is a fun, learning project, but doing it twice is masochism. I was told by NHS that they would turn them around in two days – and they did. They came back looking great and fixed my sticky tach as well. I highly recommend them for your gauge work.

I was pleasantly surprised to find that Porsche had gone to 1-piece connectors for the gauges rather than the mass of wires that were on the earlier cars. This made the whole thing a snap. Just remove the gauges and disconnect them, send the gauges off to get the faces changed and toss them back in.



## Gauge Face Installation

Here are the before and after pictures of this project.



Quite a dramatic change. Especially against the white exterior of the car.

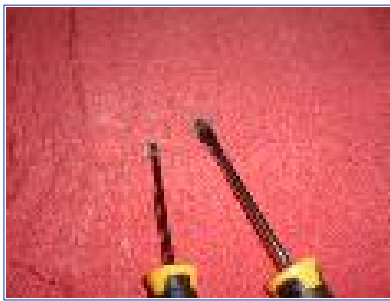

To remove the first gauge, in this case the gas gauge, I used a screwdriver that I had covered the tip with clear tape so it would not scratch the gauge during the removal.

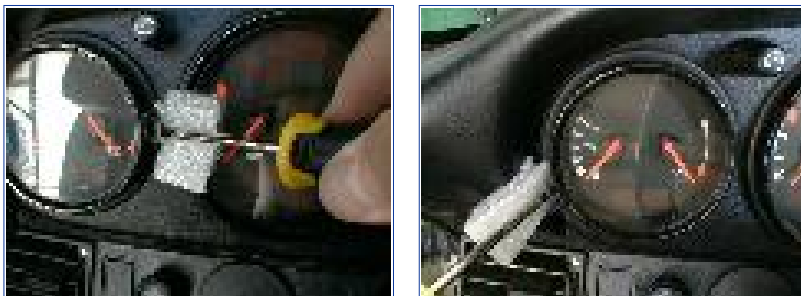

Using the screwdriver and a small piece of foam to protect the adjacent gauge and upholstery, I loosened the gauge to start removing it from the dashboard.



Once the gauge is pried away from the panel far enough you can grasp it and pull it out of the dash. Just to be on the safe side I marked each connector with a color and keyed it to the direction it attached to the gauge.



Once you have the gas gauge out you should not have to use the screwdriver again. You can now just reach through the open gauge hole and push the next gauge out with your fingers.

The tach is a little difficult to remove because of the steering wheel. You need to rotate it 180 degrees, then slip it past the steering wheel column and the gauge will come right out.



The clock has a trick to the connectors. The large connector will not come off until you disconnect the smaller black one. The smaller one is the ground connector and the soldering is weak (I broke the wire off the connector and had to re-solder it). Using a needle nose pliers to remove the metal part of the connector first will

allow you to get the plastic cover off easier.



This is what your dashboard looks like when your done – YIKES !

Be sure to take your keys out so you don't turn on the ignition by mistake. I'm not sure what effect this would have, but I didn't want to end up with a bunch of trouble codes to get cleared.



All of the gauges ready for packaging and sending off to North Hollywood Speedometer.

I was promised I would have my gauges turned around in two days and they were! The gauges looked great and you would never know they had been apart looking at the rolled edges of the bezels. Great work.

The reassembly is very easy. I did use a little trick to reinstall the gauges. I placed the rubber gaskets in the dash opening and then applied some soapy water on the inside edge as well as on the outer case of the gauge. The gauges slid right in without any problems and you have a couple of minutes to adjust them before the soapy water dries and the gauges are in tight.



Here are the pictures of the completed project. The time for removal of the gauges was about 20 minutes - and that was being extra careful. It took about half that to put them back in and fire up the car to ensure everything worked.

The white hides all of the warning lights when they are not illuminated, but when they come on they are very visible. The turn signals seem to be a lot brighter as well.

The gauges are very easy to read and all of the numbers and writing are done very well. The white gauges do seem to be very large compared to the black ones. These gauge faces are also available in silver and a variety of other colors.

---

# 964 Rear Wing Installation

I was not thrilled with the looks or the novelty of the pop up wing on my 1990 964 C2, so I decided to install a fixed rear wing to enhance the appearance and performance of the car. I chose the 3.6 RS Bridge Wing manufactured by MA Shaw. I live close to Mike and I was able to talk to him and check the fit of similar wing that he had available. It looked great and I ordered one right away.

The following is an account of the steps I took to prepare and install the wing as well as reinforce the struts and disable the wing dash warning light.

## Wing prep & installation



This what the car looked like with the stock pop up wing. No real excitement going on here!



The first step is to remove the old wing assembly. This is pretty straightforward and should only take 30 minutes or so. Remove the wiring harness all the way to the connector in the right side of the engine bay. The result is a great big hole in the rear lid.



The wing as you will receive it will have a gel coat on it that is very shiny. This has to be sanded smooth and the edges where the halves were joined will have to be sanded to take out any high spots.



You will spend more time sanding the wing than you can imagine. It is very critical that you ensure the surface is as smooth as possible and all flaws have been removed because EVERYTHING will show up when it is painted.

You can send the wing to your painters and have them sand it before painting, but this is where the majority of your money will be spent. It is a labor intensive procedure to do the sanding so you can save quit a bit if you choose to do it yourself.



After I took the wing to my painters for the primer coat he gave it back and said OK, now sand it again ! Gezz, what a slave driver. I have a whole new respect for the guys that do the sanding !

I sanded the (now) primered wing for what seemed like days and I have no fingerprints to prove it. An area that needs special attention is anywhere you get pinholes in the finish. You MUST fill them and achieve a smooth finish, as the paint cannot fill holes. It will leave your finish with little holes that appear to be dots. Not the kind of finish you want on your car after all this work.



My primed (for the second time) wing was now ready for a final fit check before going to the painter. Everything lined up perfect and I was off to the shop.



The wing I chose consisted of two parts – the base part with the spoiler and the bridge wing portion. When I got them back from Arrow Glen Body Shop in Ontario, the pieces were a perfect match to the car, buffed out and ready for installation.



I installed the screen that goes on the underside of the grill area and painted the inside satin black so it would not show through the top of the grill.



The wing fit into the opening of the C2's rear lid like a glove. I had originally intended to use a black trim piece between the base of the wing and the lid, but it looked better without it and gave the wing a more integral look.

You will also have to relocate the CARRERA 2 emblem down a couple of inches. I did this by using a piece of dental floss (my favorite is mint) after the emblem has been heated up with a hair dryer. The letters will come right off and you can clean up the area with alcohol, apply new double stick tape to the emblem and reinstall it.



This is the completed wing. It gives the car a longer, lower and more aggressive look. It is very distinctive. For under a grand it was a very worthwhile improvement.

### **Eliminating the Dash Warning Light**

The 964 has a warning light that illuminates on the dash to tell you that there is a problem with the wing. When the pop up wing is removed, the car thinks there is a problem because it cannot detect the wing function and gives you an irritating warning light. Here are the steps to take to eliminate this problem.



Note – On 1992 and later models including 993's there is a plug under the dash on the passenger side that you can just disconnect to disable the light.



On the right side of the engine compartment you will see a connector between the fuel filter and the power steering reservoir. Unhook the connector from the mounting and disconnect it. The part that remains in the car is a female plug. You are going to have to make a jumper wire to connect the #3 & #7 pins in the connector.



As you can see in the picture it is just a small wire to connect the two pins. One pin is female and the other is male. The numbers are marked inside next to the pins.



After connecting the two pins, I sealed the connector with RTV and used a plastic cap to keep moisture out. Then I reinstalled the connector half back into the mounting in the engine compartment. Keep the wiring harness to the wing motor assembly in case you ever want to reinstall the pop up wing.

### **Additional Shock Struts**

The increased weight of the new wing will overpower the stock struts, so I made up a dual strut and mounted it on the passenger's side to add additional lifting capability to the system. I only needed one extra strut to do the job.



Using an old strut I had, I made a pin that went through both of the struts and would also attach to the hinge mounting hole. I used a piece of aluminum rod in my junk drawer for



the mounting pin.



I installed one strut in the stock position and the other just to the left on the outside portion of the hinge mount. I put a wire tie on just for piece of mind.

The lid now pops right up when the handle is pulled.

---